



Contactor, 3p+2N/O+2N/C, 200kW/400V/AC3



Powering Business Worldwide™

Part no. DILM400/22(RA250)
Article no. 208209
Catalog No. XTCE400M22A

Delivery programme

Product range				Contactors
Application				Contactors for Motors
Subrange				Comfort devices greater than 170 A
Utilization category				AC-1: Non-inductive or slightly inductive loads, resistance furnaces AC-3: Squirrel-cage motors: starting, switching off during running AC-4: Squirrel-cage motors: starting, plugging, reversing, inching
Connection technique				Screw connection
Rated operational current				
AC-1				
Conventional free air thermal current, 3 pole, 50 - 60 Hz				
Open				
at 40 °C	$I_{th} = I_e$	A		612
enclosed	I_{th}	A		450
Conventional free air thermal current, 1 pole				
open	I_{th}	A		1250
enclosed	I_{th}	A		1125
Max. rating for three-phase motors, 50 - 60 Hz				
AC-3				
220 V 230 V	P	kW		125
380 V 400 V	P	kW		200
660 V 690 V	P	kW		344
1000 V	P	kW		132
AC-4				
220 V 230 V	P	kW		92
380 V 400 V	P	kW		160
660 V 690 V	P	kW		283
1000 V	P	kW		132
Contact sequence				
Can be combined with auxiliary contact				DILM820-XHI...
Actuating voltage				RA 250: 110 - 250 V 40 - 60 Hz/110 - 350 V DC
Voltage AC/DC				AC and DC operation
Contacts				
N/O = Normally open				2 N/O
N/C = Normally closed				2 NC
Auxiliary contacts				
possible variants at auxiliary contact module fitting options				on the side: 2 x DILM820-XHI11(V)-SI; 2 x DILM820-XHI11-SA
Side mounting auxiliary contacts				
Instructions				integrated suppressor circuit in actuating electronics 660 V, 690 V or 1000 V: not directly reversing

Approvals

Product Standards	IEC/EN 60947-4-1; UL 508; CSA-C22.2 No. 14-05; CE marking
UL File No.	E29096
UL Category Control No.	NLDX
CSA File No.	012528
CSA Class No.	3211-04

North America Certification	UL listed, CSA certified
Specially designed for North America	No

General

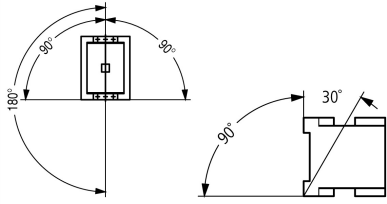
Standards			IEC/EN 60947, VDE 0660, UL, CSA
Lifespan, mechanical			
AC operated	Operations	$\times 10^6$	7
DC operated	Operations	$\times 10^6$	7
Operating frequency, mechanical			
AC operated	Operations/h		2000
DC operated	Operations/h		2000
Climatic proofing			Damp heat, constant, to IEC 60068-2-78 Damp heat, cyclic, to IEC 60068-2-30
Ambient temperature		°C	
Open		°C	- 40 - + 60
Enclosed		°C	- 40 - + 40
Storage		°C	- 40 - + 80
Mounting position			
Mechanical shock resistance (IEC/EN 60068-2-27)			
Half-sinusoidal shock, 10 ms			
Main contacts			
N/O contact		g	10
Auxiliary contacts			
N/O contact		g	10
N/C contact		g	8
Degree of Protection			IP00
Protection against direct contact when actuated from front (EN 50274)			Finger and back-of-hand proof with terminal shroud or terminal block
Weight			
AC operated		kg	8.51
DC operated		kg	8.51
Weight		kg	8.51
Terminal capacity main cable			
Flexible with cable lug		mm ²	50 - 240
Stranded with cable lug		mm ²	70 - 240
Solid or stranded		AWG	2/0 - 500 MCM
Flat conductor	Lamellenzahl x Breite x Dicke	mm	Fixing with flat cable terminal or cable terminal blocks See terminal capacity for cable terminal blocks
Busbar	Breite	mm	25
Main cable connection screw/bolt			M10
Tightening torque		Nm	24
Terminal capacity control circuit cables			
Solid		mm ²	1 x (0.75 - 2.5) 2 x (0.75 - 2.5)
Flexible with ferrule		mm ²	1 x (0.75 - 2.5) 2 x (0.75 - 2.5)
Solid or stranded		AWG	2 x (18 - 12)
Control circuit cable connection screw/bolt			M3.5
Tightening torque		Nm	1.2
Tool			
Main cable			
Open-end spanner		mm	16

Control circuit cables			
Pozidriv screwdriver		Size	2
Main conducting paths			
Rated impulse withstand voltage	U_{imp}	V AC	8000
Overvoltage category/pollution degree			III/3
Rated insulation voltage	U_i	V AC	1000
Rated operational voltage	U_e	V AC	1000
Safe isolation to EN 61140			
between coil and contacts		V AC	500
between the contacts		V AC	500
Making capacity (p.f. to IEC/EN 60947)		A	5500
Breaking capacity			
220 V 230 V		A	5000
380 V 400 V		A	5000
500 V		A	5000
660 V 690 V		A	5000
1000 V		A	950
Component lifespan			
			AC1: See -> Engineering, characteristic curves AC3: See -> Engineering, characteristic curves AC4: See -> Engineering, characteristic curves
Short-circuit rating			
Short-circuit protection maximum fuse			
Type "2" coordination			
400 V	gG/gL 500 V	A	500
690 V	gG/gL 690 V	A	500
1000 V	gG/gL 1000 V	A	200
Type "1" coordination			
400 V	gG/gL 500 V	A	630
690 V	gG/gL 690 V	A	630
1000 V	gG/gL 1000 V	A	250

AC

AC-1			
Rated operational current			
Conventional free air thermal current, 3 pole, 50 - 60 Hz			
Open			
at 40 °C	$I_{th} = I_e$	A	612
at 50 °C	$I_{th} = I_e$	A	548
at 55 °C	$I_{th} = I_e$	A	522
at 60 °C	$I_{th} = I_e$	A	500
enclosed	I_{th}	A	450
Notes			At maximum permissible ambient air temperature.
Conventional free air thermal current, 1 pole			
Note			at maximum permissible ambient air temperature
open	I_{th}	A	1250
enclosed	I_{th}	A	1125
AC-3			
Rated operational current			
Open, 3-pole: 50 – 60 Hz			
220 V 230 V	I_e	A	400
240 V	I_e	A	400
415 V	I_e	A	400
440V	I_e	A	400
500 V	I_e	A	400
660 V 690 V	I_e	A	360

1000 V	I _e	A	95
Motor rating	P	kWh	
220 V 230 V	P	kW	125
240V	P	kW	132
380 V 400 V	P	kW	200
415 V	P	kW	240
440 V	P	kW	200
500 V	P	kW	290
660 V 690 V	P	kW	344
1000 V	P	kW	132
AC-4			
Rated operational current			
Open, 3-pole: 50 – 60 Hz			
220 V 230 V	I _e	A	296
240 V	I _e	A	296
380 V 400 V	I _e	A	296
415 V	I _e	A	296
440 V	I _e	A	296
500 V	I _e	A	296
660 V 690 V	I _e	A	296
1000 V	I _e	A	95
Motor rating	P	kWh	
220 V 230 V	P	kW	92
240 V	P	kW	101
380 V 400 V	P	kW	160
415 V	P	kW	176
440 V	P	kW	186
500 V	P	kW	214
660 V 690 V	P	kW	283
1000 V	P	kW	132

Condensator operation

Individual compensation, rated operational current I _e of three-phase capacitors			
Open			
up to 525 V		A	307
690 V		A	177
Max. inrush current peak		x I _e	30
Component lifespan	Operations	x 10 ⁶	0.1
Max. operating frequency		Ops/h	200

DC

Rated operational current, open			
DC-1			
60 V	I _e	A	400
110 V	I _e	A	400
220 V	I _e	A	400
440 V	I _e	A	11
DC-3			
60 V	I _e	A	400
110 V	I _e	A	400
220 V	I _e	A	400
DC-5			
60 V	I _e	A	400
110 V	I _e	A	400
220 V	I _e	A	400

Current heat loss

3-pole at I_{th}	W	58
Current heat loss at I_e to AC-3/400 V	W	37

Magnet systems

Voltage tolerance		$x U_c$	
U_c			110 - 250 V 40-60 Hz 110 - 350 V DC
AC operated	Pick-up	$x U_c$	$0.7 \times U_{c \min} - 1.15 \times U_{c \max}$
DC operated	Pick-up	$x U_c$	$0.7 \times U_{c \min} - 1.15 \times U_{c \max}$
AC operated	Drop-out	$x U_c$	$0.2 \times U_{c \min} - 0.6 \times U_{c \max}$
DC operated	Drop-out	$x U_c$	$0.2 \times U_{c \min} - 0.6 \times U_{c \max}$
Power consumption of the coil in a cold state and $1.0 \times U_c$			
Note on power consumption			Control transformer with $u_k \approx 0.6$
Pull-in power	Pick-up	VA	450
Pull-in power	Pick-up	W	350
Sealing power	Sealing	CO	3.3
Sealing power	Sealing	VA	4.3
Sealing power	Sealing	W	3.3
Duty factor		% DF	100
Switching times at 100 % U_c (approximate values)			
Main contacts			
Closing delay		ms	80
Opening delay		ms	110
Behaviour in marginal and transitional conditions			
Sealing			
Voltage interruptions			
$(0 \dots 0.2 \times U_{c \min}) \approx 10 \text{ ms}$			Time is bridged successfully
$(0 \dots 0.2 \times U_{c \min}) > 10 \text{ ms}$			Drop-out of the contactor
Voltage drops			
$(0.2 \dots 0.6 \times U_{c \min}) \approx 12 \text{ ms}$			Time is bridged successfully
$(0.2 \dots 0.6 \times U_{c \min}) > 12 \text{ ms}$			Drop-out of the contactor
$(0.6 \dots 0.7 \times U_{c \min})$			Contactor remains switched on
Excess voltage			
$(1.15 \dots 1.3 \times U_{c \max})$			Contactor remains switched on
Pick-up phase			
$(0 \dots 0.7 \times U_{c \min})$			Contactor does not switch on
$(0.7 \times U_{c \min} \dots 1.15 \times U_{c \max})$			Contactor switches on with certainty
Admissible transitional contact resistance (of the external control circuit device when actuating A11)	m Ω		≈ 500
PLC signal level (A3 - A4) to IEC/EN 61131-2 (type 2)			
High	V		15
Low	V		5

Electromagnetic compatibility (EMC)

Electromagnetic compatibility			This product is designed for operation in industrial environments (environment 2). The use in residential environments (environment 1) could cause electrical interference so that addition suppression must be planned.
-------------------------------	--	--	--

Data for design verification according to IEC/EN 61439

Technical data for design verification			
Rated operational current for specified heat dissipation	I_n	A	400
Heat dissipation per pole, current-dependent	P_{vid}	W	12.33
Equipment heat dissipation, current-dependent	P_{vid}	W	0
Static heat dissipation, non-current-dependent	P_{vs}	W	3.3
Heat dissipation capacity	P_{diss}	W	0

IEC/EN 61439 design verification		
10.2 Strength of materials and parts		
10.2.2 Corrosion resistance		Meets the product standard's requirements.
10.2.3.1 Verification of thermal stability of enclosures		Meets the product standard's requirements.
10.2.3.2 Verification of resistance of insulating materials to normal heat		Meets the product standard's requirements.
10.2.3.3 Verification of resistance of insulating materials to abnormal heat and fire due to internal electric effects		Meets the product standard's requirements.
10.2.4 Resistance to ultra-violet (UV) radiation		Meets the product standard's requirements.
10.2.5 Lifting		Does not apply, since the entire switchgear needs to be evaluated.
10.2.6 Mechanical impact		Does not apply, since the entire switchgear needs to be evaluated.
10.2.7 Inscriptions		Meets the product standard's requirements.
10.3 Degree of protection of ASSEMBLIES		Does not apply, since the entire switchgear needs to be evaluated.
10.4 Clearances and creepage distances		Meets the product standard's requirements.
10.5 Protection against electric shock		Does not apply, since the entire switchgear needs to be evaluated.
10.6 Incorporation of switching devices and components		Does not apply, since the entire switchgear needs to be evaluated.
10.7 Internal electrical circuits and connections		Is the panel builder's responsibility.
10.8 Connections for external conductors		Is the panel builder's responsibility.
10.9 Insulation properties		
10.9.2 Power-frequency electric strength		Is the panel builder's responsibility.
10.9.3 Impulse withstand voltage		Is the panel builder's responsibility.
10.9.4 Testing of enclosures made of insulating material		Is the panel builder's responsibility.
10.10 Temperature rise		The panel builder is responsible for the temperature rise calculation. Eaton will provide heat dissipation data for the devices.
10.11 Short-circuit rating		Is the panel builder's responsibility. The specifications for the switchgear must be observed.
10.12 Electromagnetic compatibility		Is the panel builder's responsibility. The specifications for the switchgear must be observed.
10.13 Mechanical function		The device meets the requirements, provided the information in the instruction leaflet (IL) is observed.

Technical data ETIM 5.0

Low-voltage industrial components (EG000017) / Magnet contactor, AC-switching (EC000066)			
Electric engineering, automation, process control engineering / Low-voltage switch technology / Contactor (LV) / Power contactor, AC switching (ecl@ss8-27-37-10-03 [AAB718011])			
Rated control supply voltage U_s at AC 50HZ	V		110 - 250
Rated control supply voltage U_s at AC 60HZ	V		110 - 250
Rated control supply voltage U_s at DC	V		110 - 250
Voltage type for actuating			AC/DC
Rated operation current I_e at AC-1, 400 V	A		612
Rated operation current I_e at AC-3, 400 V	A		400
Rated operation power at AC-3, 400 V	kW		200
Rated operation current I_e at AC-4, 400 V	A		296
Rated operation power I_e at AC-4, 400 V	kW		160
Modular version			No
Number of auxiliary contacts as normally open contact			2
Number of auxiliary contacts as normally closed contact			2
Connection type main current circuit			Rail connection
Number of normally closed contacts as main contact			0
Number of main contacts as normally open contact			3

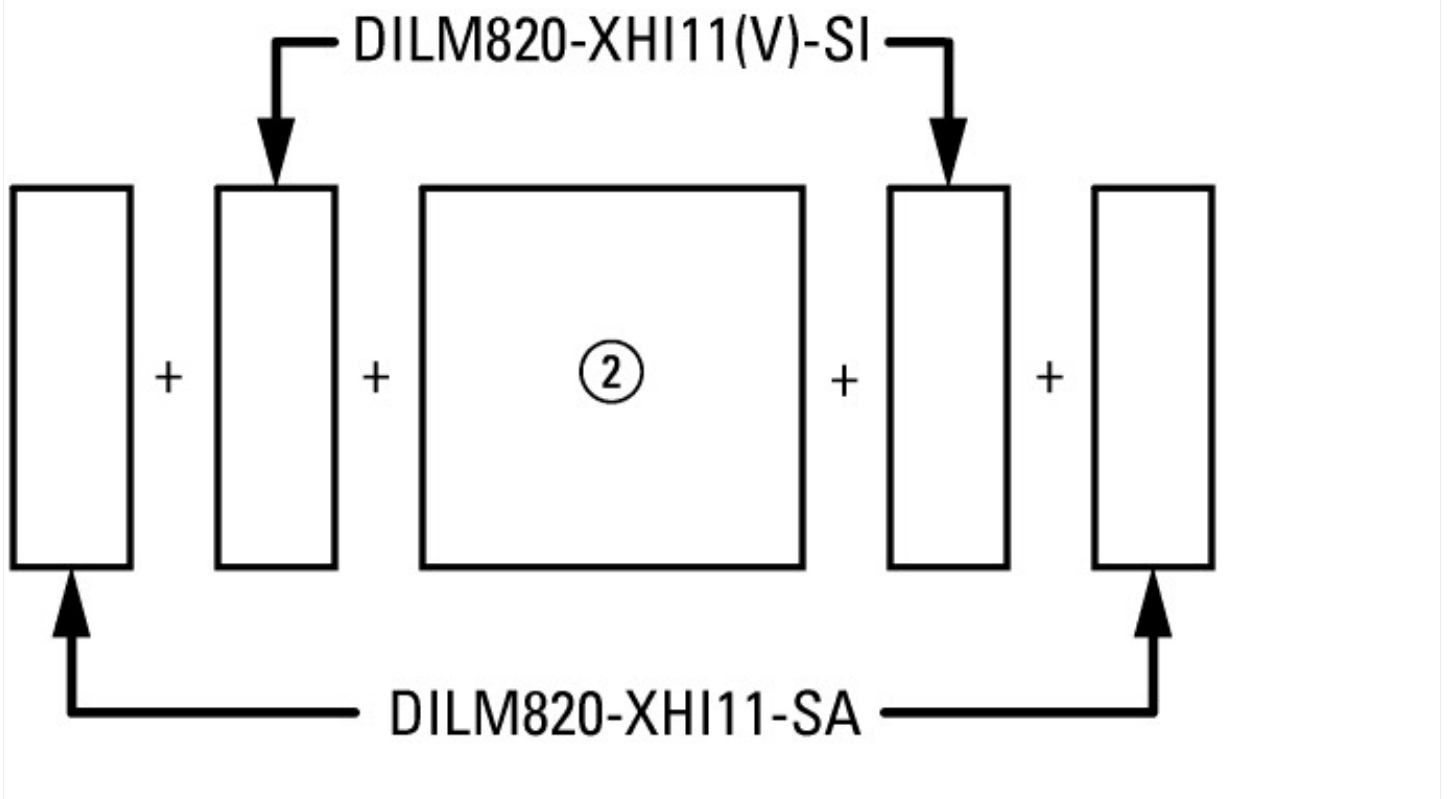

on the side: 2 x DILM820-XHI11(V)-SI; 2 x DILM820-XHI11-SA

Characteristic curves

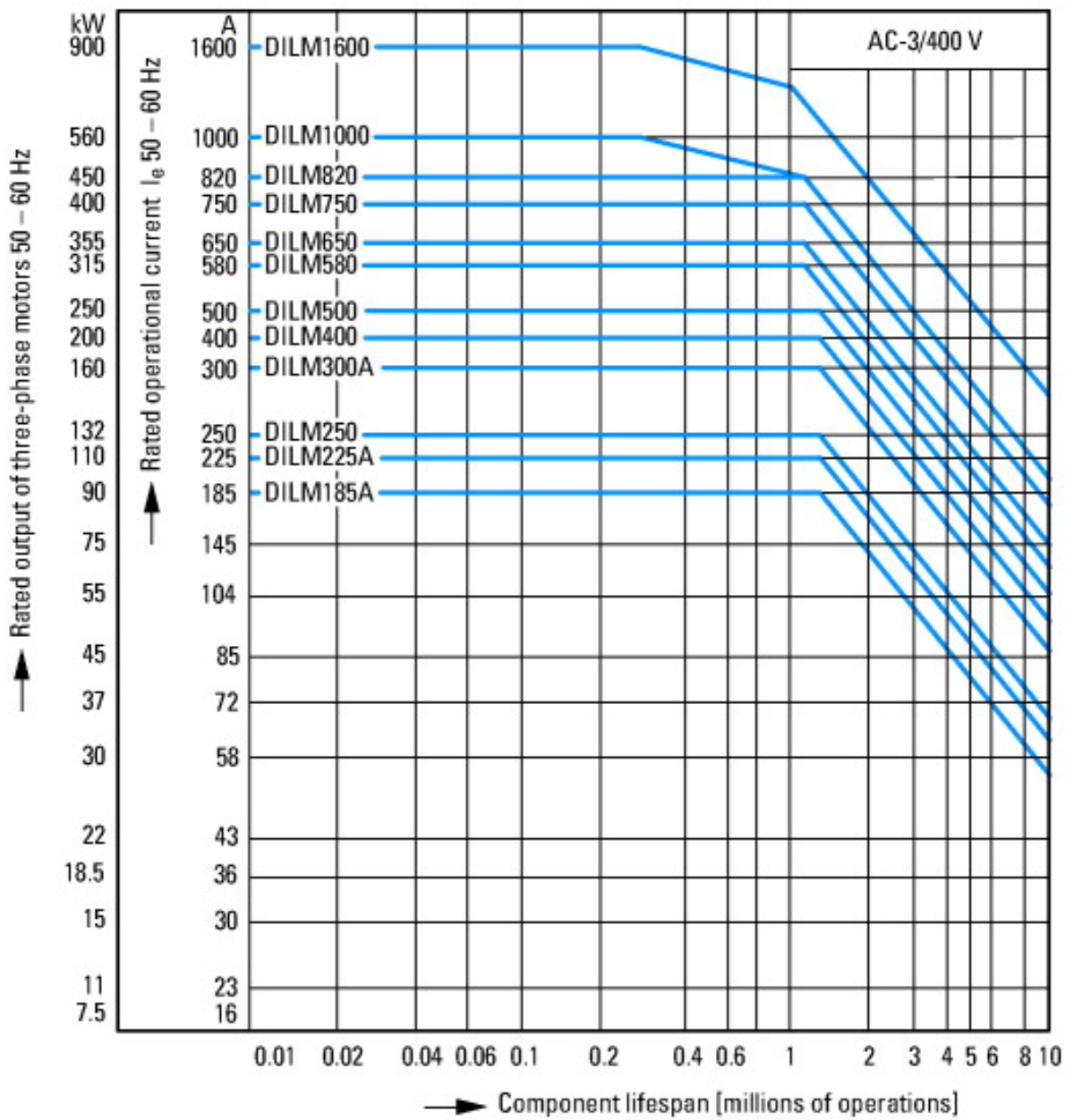

- Normal switching duty
- Normal AC induction motor
- Operating characteristics
- Switch on: from stop
- Switch off: during run
- Electrical characteristics:
- Switch on: up to 6 x Rated motor current
- Switch off: up to 1 x Rated motor current
- Utility category
- 100 % AC-3
- Typical Applications
- Compressors
- Lifts
- Mixers
- Pumps
- Escalators
- Agitators
- fan
- Conveyor belts
- Centrifuges
- Hinged flaps
- Bucket-elevator
- Air-conditioning systems
- General drives for manufacturing and processing machines

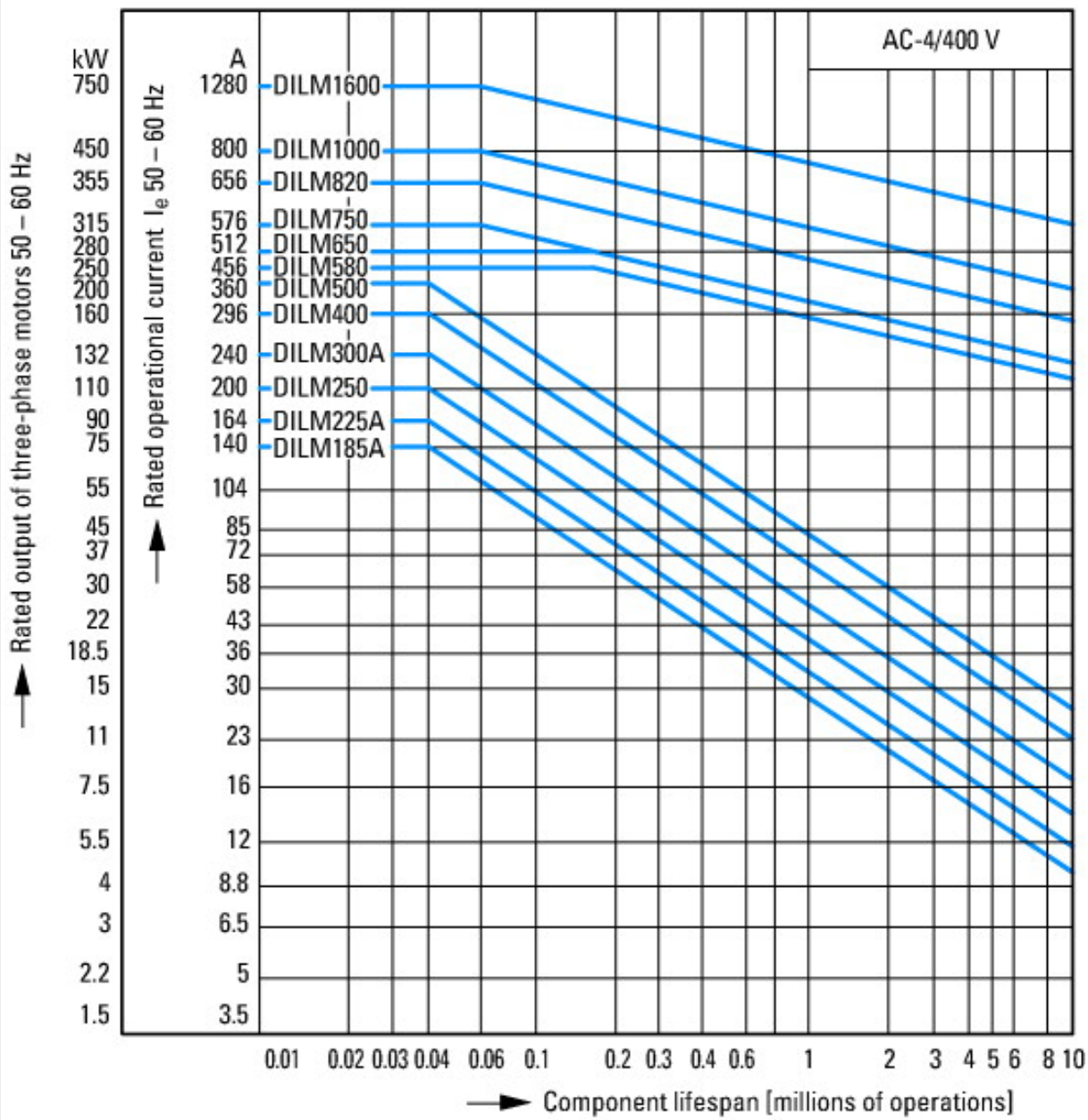

Extreme switching duty
 Squirrel-cage motor
 Operating characteristics
 Inching, plugging, reversing
 Electrical characteristics
 Make: up to 6 x rated motor current
 Break: up to 6 x rated motor current
 Utilization category
 100 % AC-4
 Typical applications
 Printing presses
 Wire-drawing machines
 Centrifuges
 Special drives for manufacturing and processing machines

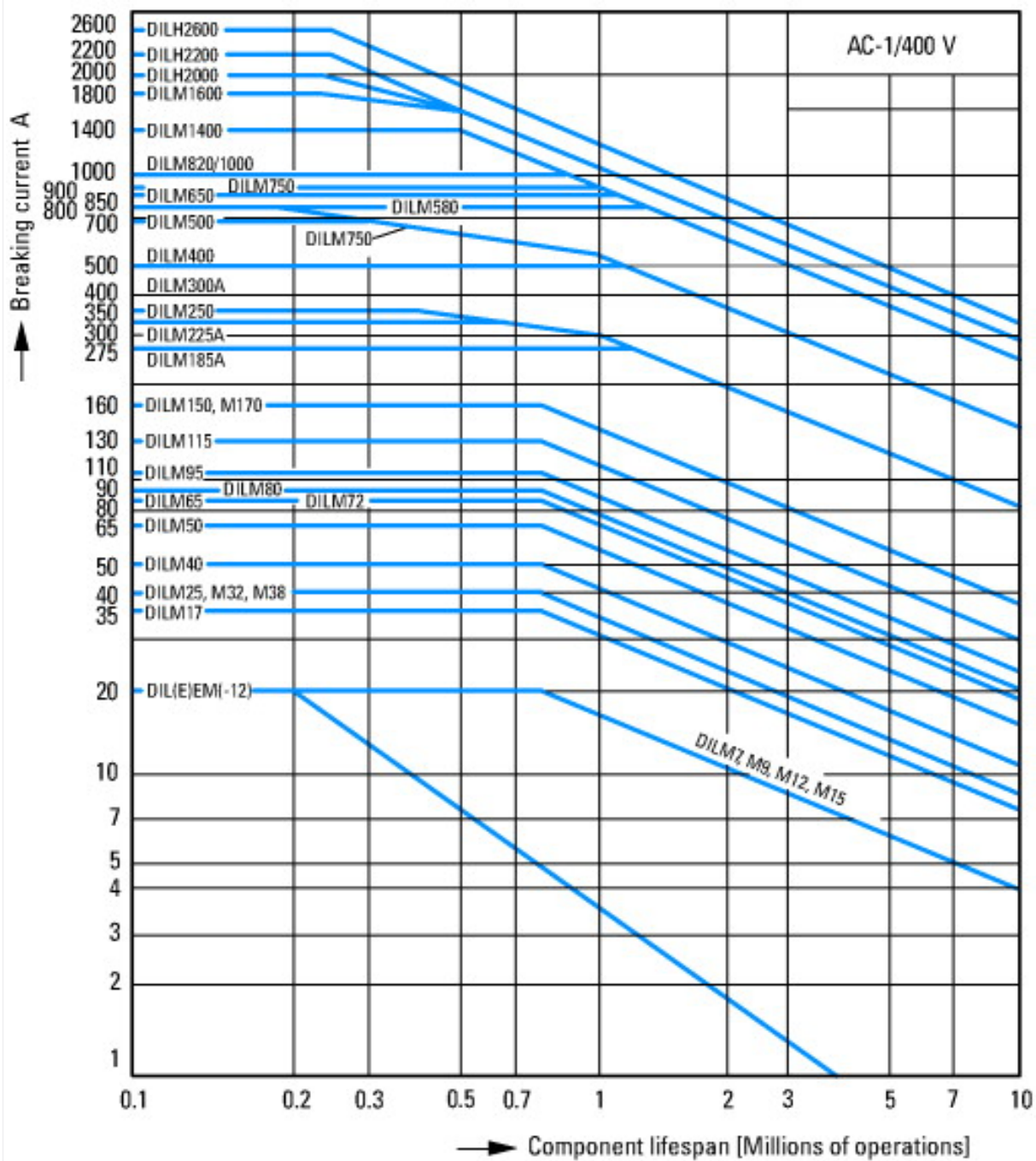

Switching duty for non-motor loads, 3-pole, 4-pole
 Operating characteristics
 Non-inductive or slightly inductive loads
 Electrical characteristics
 Make: 1 x rated current
 Break: 1 x rated current
 Utilization category
 100 % AC-1
 Typical applications
 Electric heat

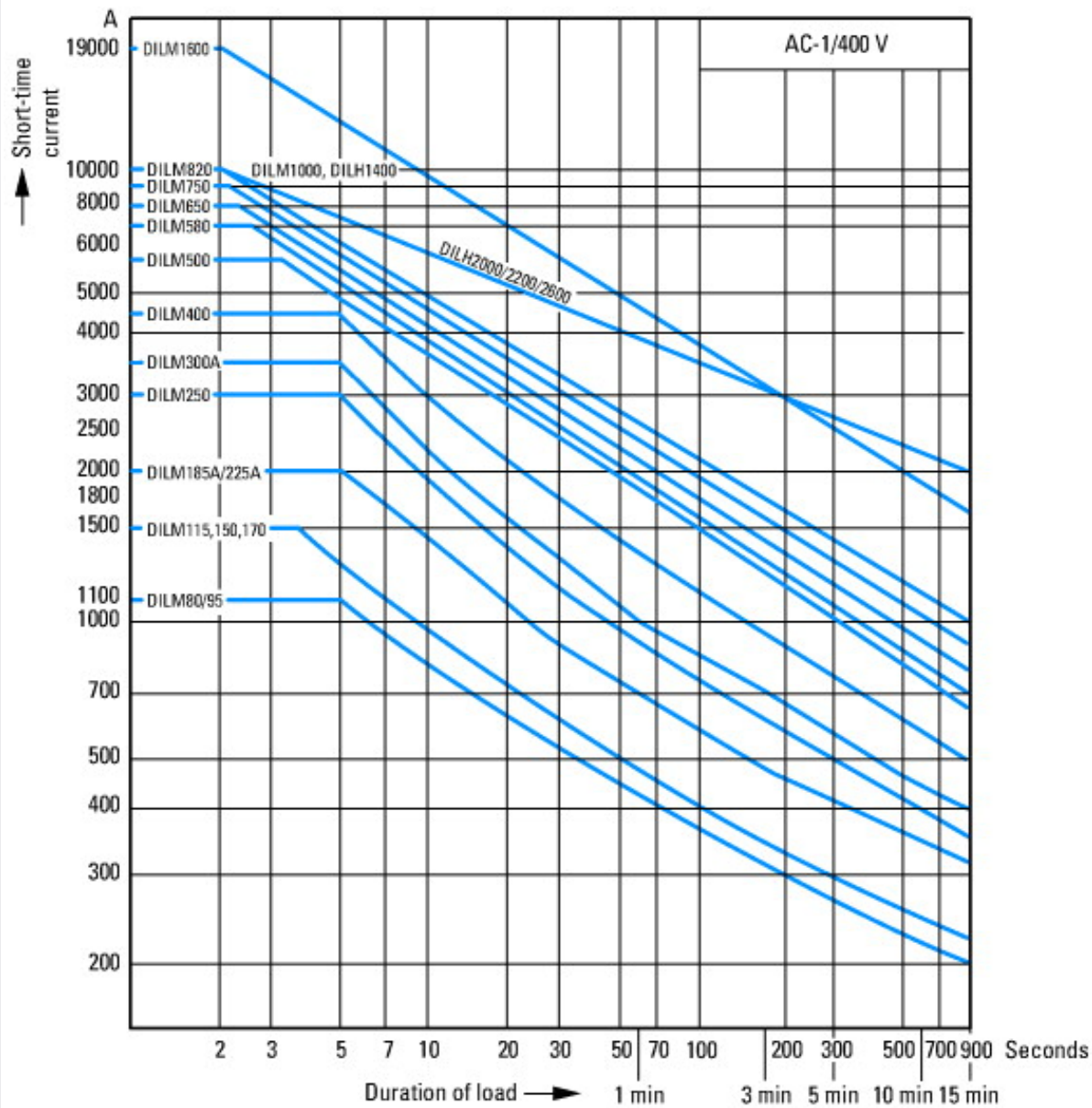

Short-time loading, 3-pole
Time interval between two loading cycles: 15 minutes

Dimensions

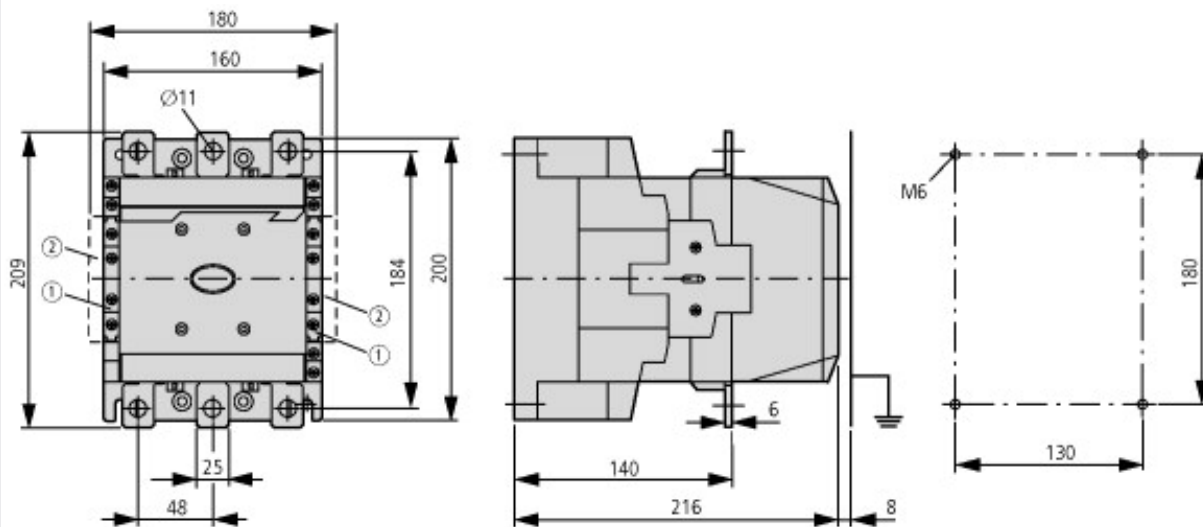

- ① DILM820-XHI11(V)-SI
- ② DILM820-XHI11-SA

Additional product information (links)

IL03406002Z (AWA2100-1639) Contactors >170 A	
IL03406002Z (AWA2100-1639) Contactors >170 A	ftp://ftp.moeller.net/DOCUMENTATION/AWA_INSTRUCTIONS/IL03406002Z2012_09.pdf
UL/CSA: Approved rating data	http://de.ecat.moeller.net/flip-cat/?edition=HPLTE&startpage=5.84
UL/CSA: UL/CSA: Short Circuit Current Rating (SCCR)	http://de.ecat.moeller.net/flip-cat/?edition=HPLTE&startpage=5.86
Switchgear of Power Factor Correction Systems	http://www.moeller.net/binary/ver_techpapers/ver934en.pdf
X-Start - Modern Switching Installations Efficiently Fitted and Wired Securely	http://www.moeller.net/binary/ver_techpapers/ver938en.pdf
Mirror Contacts for Highly-Reliable Information Relating to Safety-Related Control Functions	http://www.moeller.net/binary/ver_techpapers/ver944en.pdf
Effect of the Cable Capacitance of Long Control Cables on the Actuation of Contactors	http://www.moeller.net/binary/ver_techpapers/ver949en.pdf
Motor starters and "Special Purpose Ratings" for the North American market	http://www.moeller.net/binary/ver_techpapers/ver953en.pdf
Switchgear for Luminaires	http://www.moeller.net/binary/ver_techpapers/ver955en.pdf
Standard Compliant and Functionally Safe Engineering Design with Mechanical Auxiliary Contacts	http://www.moeller.net/binary/ver_techpapers/ver956en.pdf
The Interaction of Contactors with PLCs	http://www.moeller.net/binary/ver_techpapers/ver957en.pdf
Busbar Component Adapters for modern Industrial control panels	http://www.moeller.net/binary/ver_techpapers/ver960en.pdf