

KW4M Eco-POWER METER

Simple Wattmeter

On the lookout for wasted electricity
in buildings and plants



(DIN48x48 size)

For maintenance and control in applications involving energy saving and environmental protection

Integrated electrical energy

Voltage

Current

Electricity charge

Keeping a watchful eye.

Large display for increased visibility

Expanded basic functions

1 model supports 4 compact CTs

Supports 400 V AC power measurement *When using external voltage transformer

Eco-3 Brothers



Eco-COUNT METER



Eco-POWER METER



Eco-HOUR METER

KW4M Eco-POWER METER
ARCT1B256E-2 '06.11

New

On the lookout for wasted electricity! KW4M

FEATURES



Dedicated CT

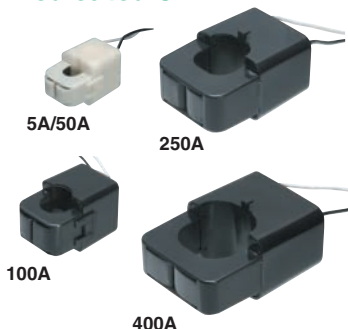

Supports 4 types of dedicated CT sensors to cover wide measuring range

Covers a wide measuring range with support for 4 types of CT (current transformer: sold separately). Also supports 5 A CT of secondary current input. However, when inputting a secondary current of 5 A, use a 2-stage configuration by combining with a dedicated CT.

*4 types of dedicated CT: 5 A/50 A, 100 A, 250 A, and 400 A

Support for 400 V AC power measurement

Capable of 100 V to 400 V AC power measurement. (If 240 V AC or higher, use with external voltage transformer.)

Basic functions expanded for easier operation

- Instantaneous electrical power display is possible in addition to integrated electrical energy.

- For all power supplies each phase voltage and current display are possible.

- Built-in hour meter function.

- Ability to display an integrated measured power range of up to 9999.99 MWh.

Precise power surveillance is possible by being able to display down to two decimal places. Also, the display can be expanded from a 6-digit to a 9-digit display, making it is possible to display up to 9999999.99 kW.

(9-digit display shown.)

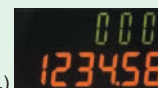

- Built-in pulse input function (cannot be used when measuring power).

CT is 1/3 the size of our previous models to save space and install more easily.

A compact CT (current transformer) is used that is approximately 1/3 the size of previous models.

Easily connects to PLC

An RS485 communications port comes standard. Up to 99 units can be connected to a PLC (when using our recommended model). Using MEWTOCOL as the protocol, it is easy to connect to a DLU (Web Datalogger Unit).

Easy operation with shortcut key



Letters are easy to read with 16-segment LCD

Instantaneous electrical power/ Integrated electrical energy

Since "Instantaneous electrical power" can be displayed, you can instantly verify the power being used at the current time.

Current (L1/L2)

Voltage (1-2/2-3)

Electricity charge (yen/dollar/euro/yuan)

Charge display supports four currencies: yen, dollar, euro, and yuan.

Load time (ON/OFF)

Since an hour meter function is built in, you can measure the power-on time that is over or under the control current.

Count value/Preset value

A counter function is built in. By using this "pulse input", surveillance other than the electrical power is possible of the integrated energy in the air or a gas.

PRODUCT TYPES

Main unit

Phase and wire system	Rated input	Current transformer	Terminal type	Part No.
Single-phase two-wire system	100 to 120/ 200 to 240V AC	Dedicated CT type (5 A/50 A/100 A/ 250 A/400 A)	Screw terminal	AKW5111
Single-phase three-wire system			11-pins	AKW5211
Three-phase three-wire system				

Choosing a CT

		(5A/50A) AKW4801	(100A) AKW4802	(250A) AKW4803	(400A) AKW4804
KW4S (AKW4111/4211)	Dedicated CT	A	N/A	N/A	N/A
	Commercial CT	N/A	Please refer to the types of commercial CTs we recommend ^{Note 2)} .		
KW4M (AKW5111/5211)	Dedicated CT	A	A	A	A

Notes 1: A: Available, N/A: Not available

2: The commercial CT should have a secondary current rating of 1A.

Dedicated current transformer (CT)

Rated primary current	Part No.
5A/50A	AKW4801
100A	AKW4802
250A	AKW4803
400A	AKW4804

PART NAME

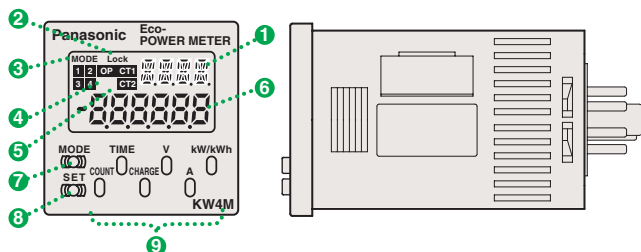

1 Mode indicator (16-segment LCD)

2 Lock indicator Illuminates when locked.

3 Mode indicator Illuminates when setting a mode.

4 Output indicator Illuminates during pulse output.

5 CT direction notification display Illuminates when the CT direction is correct and a current flows that exceeds the set current value.

6 Value display (7-segment) Displays the integrated electrical energy, instantaneous electrical power, current, voltage, electricity charge, hour meter time, count, and all settings.

7 MODE key Used to move between different modes.

8 SET key Used to make settings.

9 Select key Changes the item displayed.

Used to move between modes.

Eco-POWER METER Features and Specifications

SPECIFICATIONS

Measurement items

Item		Unit	Data range
Instantaneous electrical power		kW	0.00 to 9999.99
Integrated electrical energy		kWh	0.00 to 9999.99kWh to 10.00MWh to 9999.99MWh
		MWh	
Current	L1 (CT1) phase current	A	0.0 to 999.9
	L2 (CT2) phase current	A	0.0 to 999.9
Voltage	Voltage between 1-2	V	0.0 to 9999.9
	Voltage between 2-3	V	0.0 to 9999.9
Electricity charge *1	Yen	JPY	0 to 999999
	Dollars	\$	0 to 9999.99
	Euros	EUR	0 to 9999.99
	Yuan	CNY	0 to 9999.99
Hour meter	ON time	h (Hour)	0.0 to 99999.9
	OFF time	h (Hour)	0.0 to 99999.9
Pulse input		Count	0 to 999999

*1: Electricity charge is designed chiefly for managing energy saving. It is not intended to be used for billing.

Main unit

Rated operating voltage	100 to 120/200 to 240V AC
Rated frequency	50/60 Hz common
Rated power consumption	8VA
Allowable operating voltage range	85 to 132/170 to 264V AC (85% to 110% of rated operating voltage)
Allowable power off time	10ms
Ambient temperature	-10°C to +50°C +14°F to +122°F (Storage temperature: -25°C to +70°C -13°F to 158°F)
Ambient humidity	30 to 85%RH (at 20°C non-condensing)
Display method	With Backlight 6-digit, 7-segment LCD for settings and 4-digit, 16-segment LCD for modes. Upper display: green, Lower display: amber
Power failure memory method	EEP-ROM (Over 100,000 overwrites)
Protective construction	IP66 (front panel with rubber gasket) Note: Waterproofing (IP66) will be lost in continuous (permanently attached) installations.
Mass	For 11-pin type: approx. 130 g, For Screw terminal type: approx. 140 g

Communication

Interface	Conforming to RS485
Protocol	MEWTOCOL
Number of connected units	Max. 99 units
Transmission distance	Max. 1,200m

Pulse input

Input mode	Addition (fixed)
Max. counting speed	2 kHz/30 Hz (selectable by mode)
Pulse input	Min. input signal width: 0.25 ms (when 2 kHz selected)/16.7 ms (when 30 Hz selected) ON : OFF ratio = 1 : 1
Input signal	Contact/No contact (open collector) • Impedance when shorted: 1 kΩ • Residual voltage when shorted: Max. 2 V • Impedance when open: 100 kΩ
Output mode	HOLD (over count)
Number of digits	6 digits display (0 to 999999) (selectable by mode)

Pulse output (transistor output)

Number of output points	1 point
Insulation method	Optical coupler
Output type	Open collector
Output capacity	100mA 30V DC
Pulse width	Approx. 100ms
ON state voltage drop	1.5V or less
OFF state leakage current	100 μA or less
Pulse output unit *2	When measuring power: 0.001/0.01/0.1/1/10/100 kWh/Alarm (selectable by mode) When measuring pulse input: HOLD (over count)

*2 Power and pulse input are not possible at the same time.

System configuration examples

1 Electric power watching in manufacturing lines

Example 1 Electric power watching using PLC with Eco-POWER METER

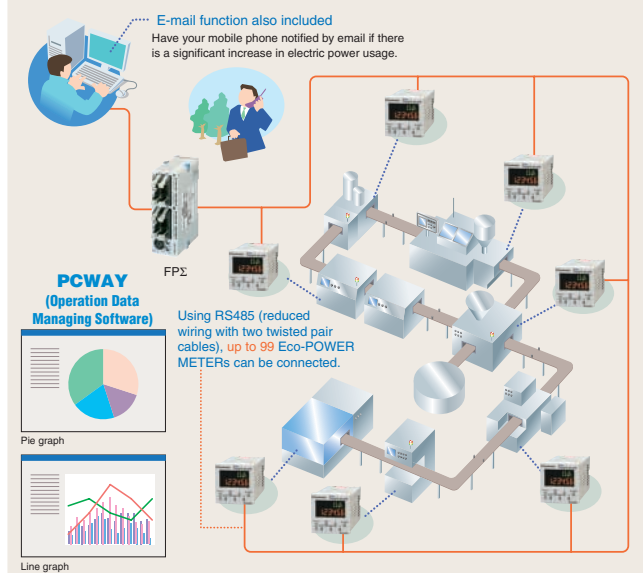

2 Electric power data collection and remote watching of plants and buildings

Example 2 Electric power watching using Web Datalogger Unit with Eco-POWER METER

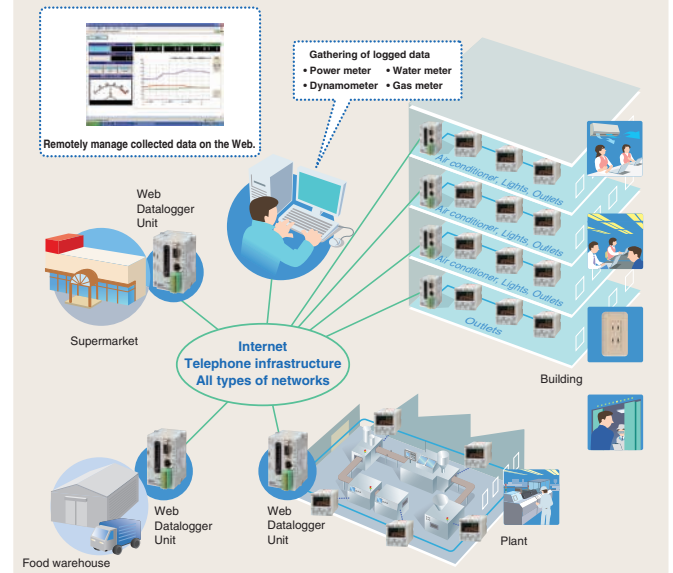

KW4M Eco-POWER METER

■ **Dimensions** (mm inch) General tolerance: $\pm 1.0 \pm 0.039$

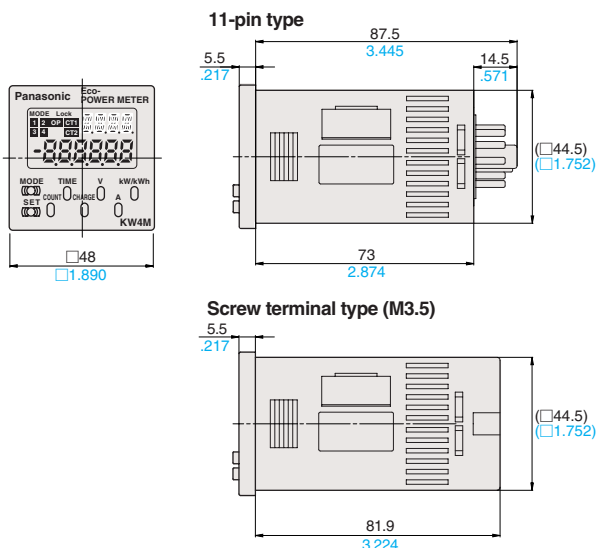

■ Terminal Layouts and Wiring Diagrams

● Single-phase, two-wire connection

*One current transformer (CT) is required for measurement with single-phase, two-wire systems.

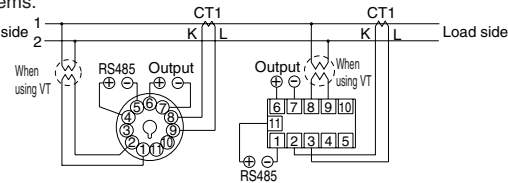

● Single-phase, three-wire and three-phase, three-wire connections

*Two current transformers (CT) are required for measurement with single-phase, three-wire and three-phase, three-wire systems.

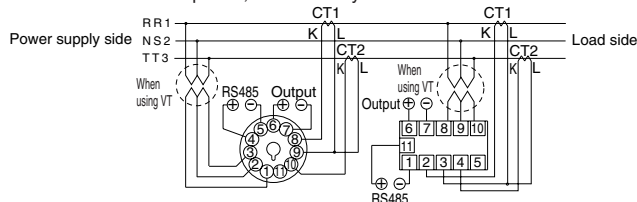

● Terminal layouts

No.	11-pin type	Screw terminal type
1	1, R, R	RS-485 (-)
2	2, N, S	CT1 (K)/IN
3	3, T, T	CT1 (L), CT2 (L)
4	RS-485 (+)	CT2 (K)
5	RS-485 (-)	0V
6	Pulse output (+)	Pulse output (+)
7	Pulse output (-)	Pulse output (-)
8	CT1 (K)/IN	1, R, R
9	CT1 (L), CT2 (L)	2, N, S
10	CT2 (K)	3, T, T
11	0V	RS-485 (+)

- For correct usage, please read "Installation Instructions" thoroughly before using.
- For details, specifications and handling, please refer to the KW4M Eco-POWER METER user's manual.
- The user's manual can be downloaded from <http://www.mew.co.jp/ac/e/download/index.html>.

KW4S Eco-POWER METER

1. Electricity meter that acts like an industrial component (DIN size: 48×48)

Eco-POWER METER is both compact and inexpensively priced. It is easy to install on your existing equipment and machinery.

2. Digitally display integrated electrical energy and electricity charges

You can digitally display integrated electrical energy, voltage, current, and electricity charges. This is handy for managing energy-saving.

● Product types

Product name	Phase and wire system	Rated input	Current transformer	Terminal type	Part No.
Eco-POWER METER main unit	Single-phase two-wire system Single-phase three-wire system Three-phase three-wire system	100 to 120/ 200 to 240V AC	Dedicated CT type	Screw terminal	AKW4111
				11-pin	AKW4211
			Commercial CT type (Rated secondary current: 1 A)	Screw terminal	AKW4121
				11-pin	AKW4221
Dedicated current transformer (CT)	Can be used with AKW4111 and AKW4211 (For KW4M Eco-POWER METER, AKW5111 and AKW5211.)			AKW4801	
Data collection software for Eco-POWER METER	Setting of any parameter, and editing and monitoring of all measurement values. Downloadable from http://www.mew.co.jp/ac/e/download/index.html			KW Monitor	

- Please refer to "Eco-3 Brothers (ARCT1B226E-1)" catalog.

3. Log and track data of integrated electrical energy usage

It is easy to load the power usage pulse output into a PLC or counter.

4. Centrally manage integrated electrical energy, voltage, and current

Adopts the RS485 for communication specification. This allows you to log data (integrated electrical energy, voltage, and current) from up to 99 units on a PC and PLC.



Dedicated CT



Eco-POWER METER

These materials are printed on ECF pulp.
These materials are printed with earth-friendly vegetable-based (soybean oil) ink.



Please contact

Matsushita Electric Works, Ltd.

Automation Controls Business Unit

■ Head Office: 1048, Kadoma, Kadoma-shi, Osaka 571-8686, Japan

■ Telephone: +81-6-6908-1050 ■ Facsimile: +81-6-6908-5781

<http://www.mew.co.jp/ac/e/>

Panasonic®

All Rights Reserved © 2006 COPYRIGHT Matsushita Electric Works, Ltd.