



**The cost effective maintenance solution for luminaires**

### FEATURES

- Designed for general use of high bay light fittings.

### TYPICAL APPLICATIONS

- Workshops, Factories, Warehouses, Showrooms, Theatres where high bay lights are fixed.

### PRODUCT TYPE

|                                 | YBC08604 | YBC0860420 |
|---------------------------------|----------|------------|
| Maximum lowering distance       | 15m      | 20m        |
| Maximum weight of light fitting | 12kg     |            |

### PATENTS

Major European patents are granted.



\* The high bay light is not included in luxlift.

## SPECIFICATIONS

### 1. Rated specifications

|                                       | YBC08604              | YBC0860420 |
|---------------------------------------|-----------------------|------------|
| Operating voltage and frequency       | AC230V 50Hz           |            |
| Power input                           | 64W                   |            |
| Current                               | 0.3A                  |            |
| Net weight (incl. stabilising weight) | 5.9kg (6.9kg)         |            |
| Dimensions (H x W x D)                | 196mm x 317mm x 230mm |            |
| Ambient temperature                   | -15°C to 40°C         |            |

### 2. Construction

|                  | YBC08604                          | YBC0860420 |
|------------------|-----------------------------------|------------|
| Protection class | IP20                              |            |
| Insulation class | Class E                           |            |
| Suspension belt  | stainless steel, W 12mm, t 0.11mm |            |
| Motor            | DC Motor                          |            |

### 3. Lowering/raising specification

|                         | YBC08604        | YBC0860420 |
|-------------------------|-----------------|------------|
| Weight of light fitting | 1 – 12kg        |            |
| Lowering height         | 15m             | 20m        |
| Lowering/Raising speed  | 3.0 – 3.6m/min. |            |

### 4. Lamp circuits

|                 | YBC08604          | YBC0860420 |
|-----------------|-------------------|------------|
| No. of circuits | 2                 |            |
| No. of contacts | 4                 |            |
| Capacity        | 12A, 400V/circuit |            |

### 5. Standards and regulations

|               | YBC08604  | YBC0860420 |
|---------------|---|------------|
| Standards     | VDE approval<br>EN55014-1, EN61000-3-2, EN61000-3-3, EN61000-6-2, EN60335-1, EN292-1, EN292-2, VBG8 |            |
| EC directives | CE marking<br>Machines(98/37/EEC)<br>EMC(89/336/EEC)<br>Low voltage (73/23/EEC)                     |            |

# CHARACTERISTICS

## Exposed view of YBC08604

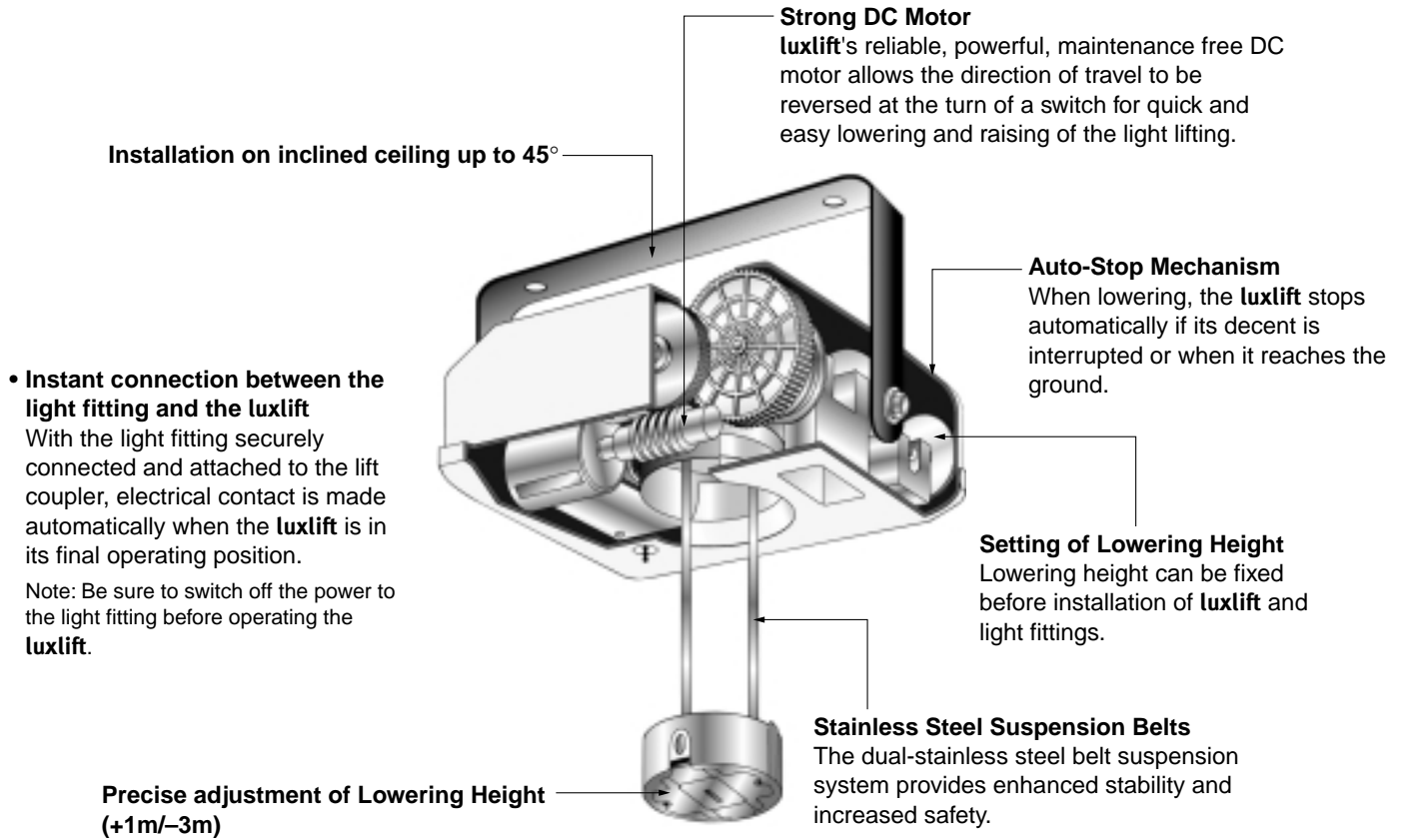

## Adjustment of lowering height

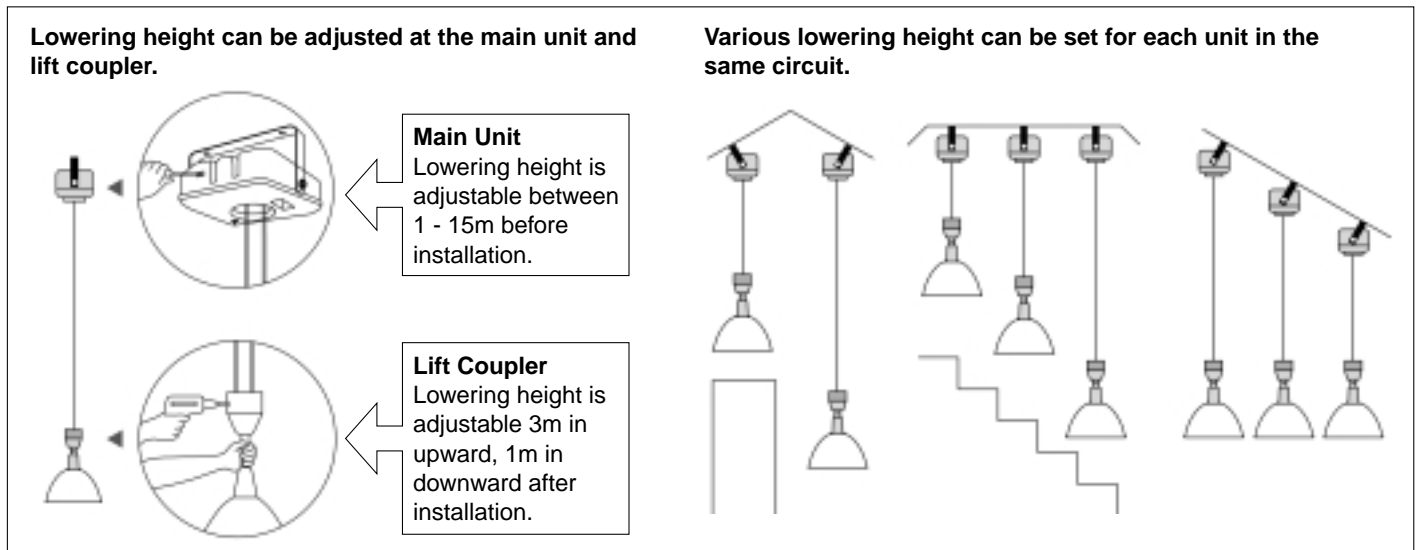

# DIMENSIONS

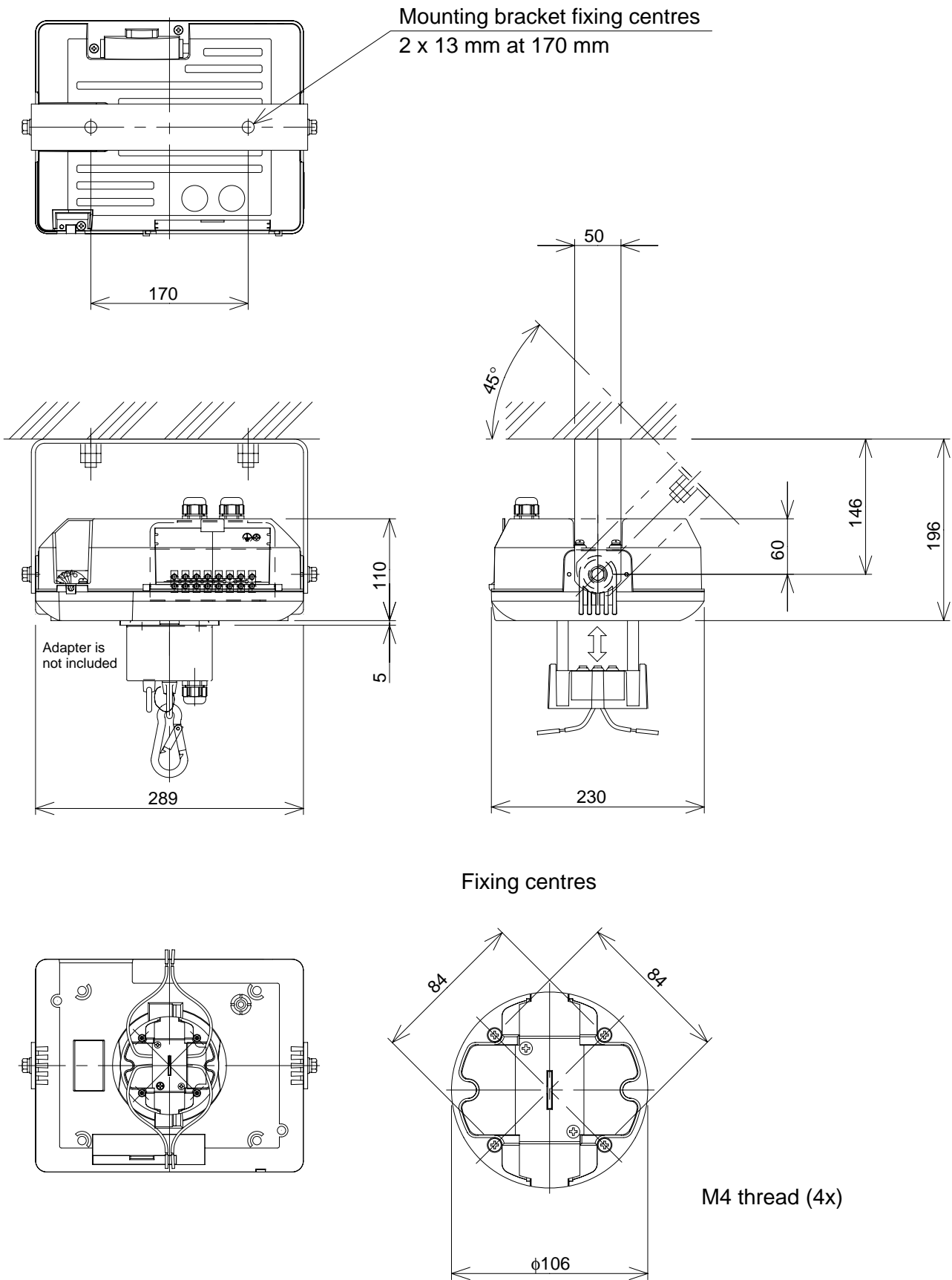

All dimensions are in mm.

## INSTALLATION

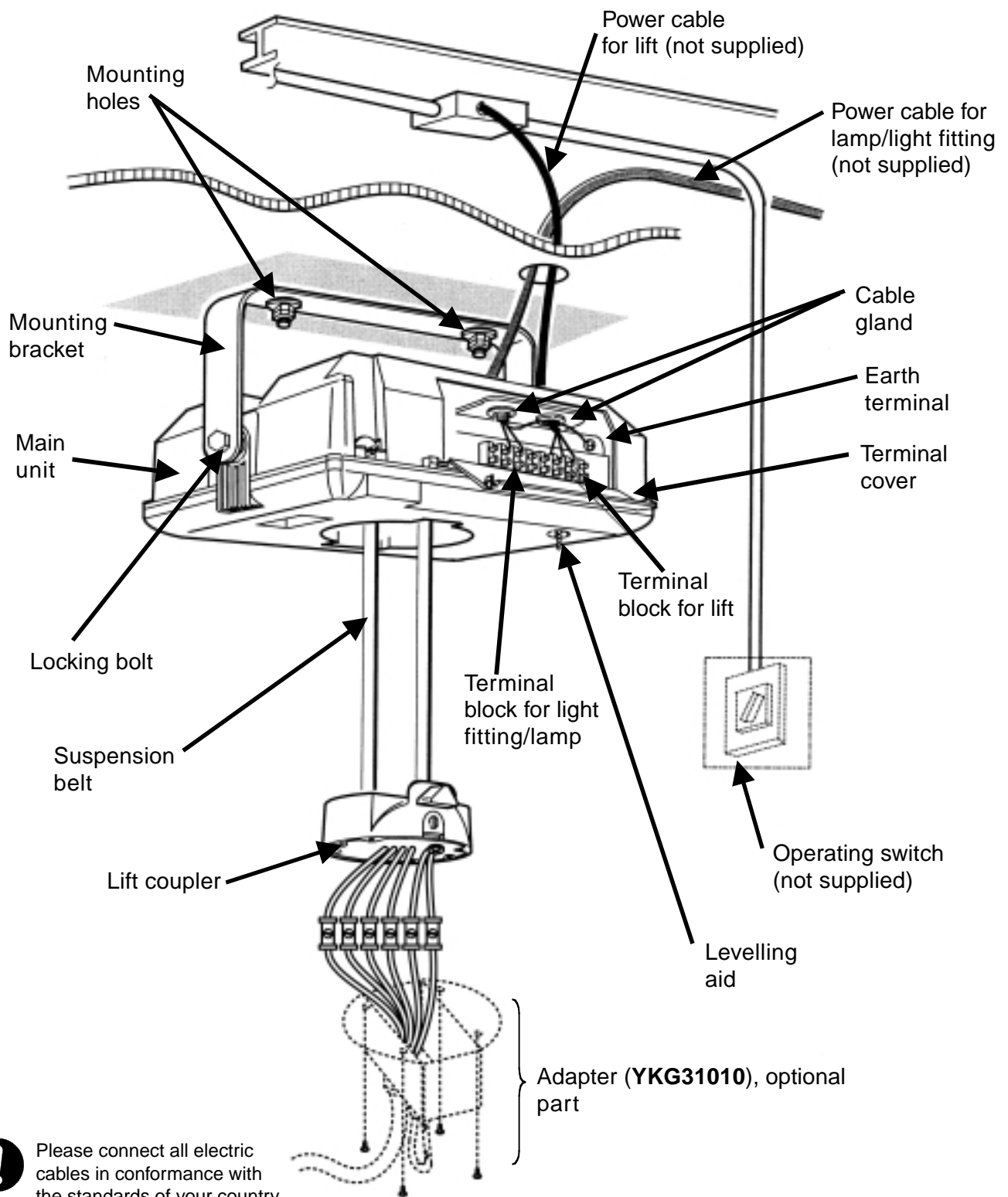

Please connect all electric cables in conformance with the standards of your country.



In case of using the adaptor other than YKG31010 prepared by the installer, the adaptor must conform to VDE and concerned electrical standards.

## INSTALLATION EXAMPLES

• With pendant type light fitting

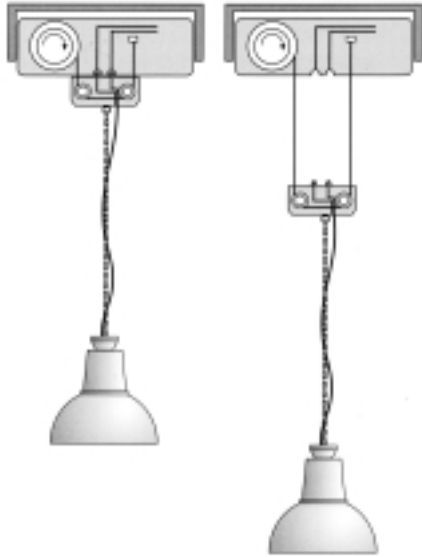

• In false ceiling

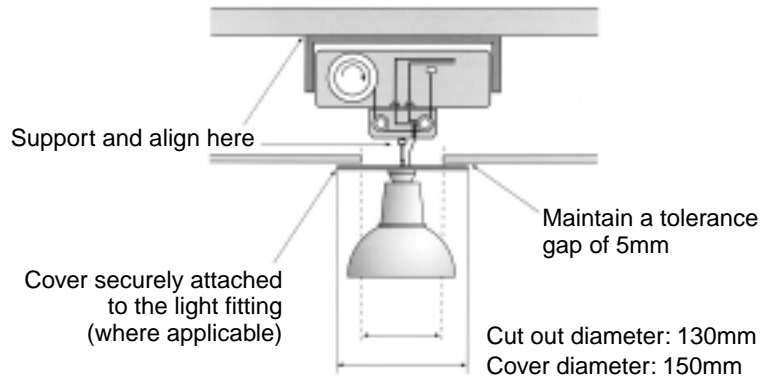

## WIRING DIAGRAM

Connection of luxlift

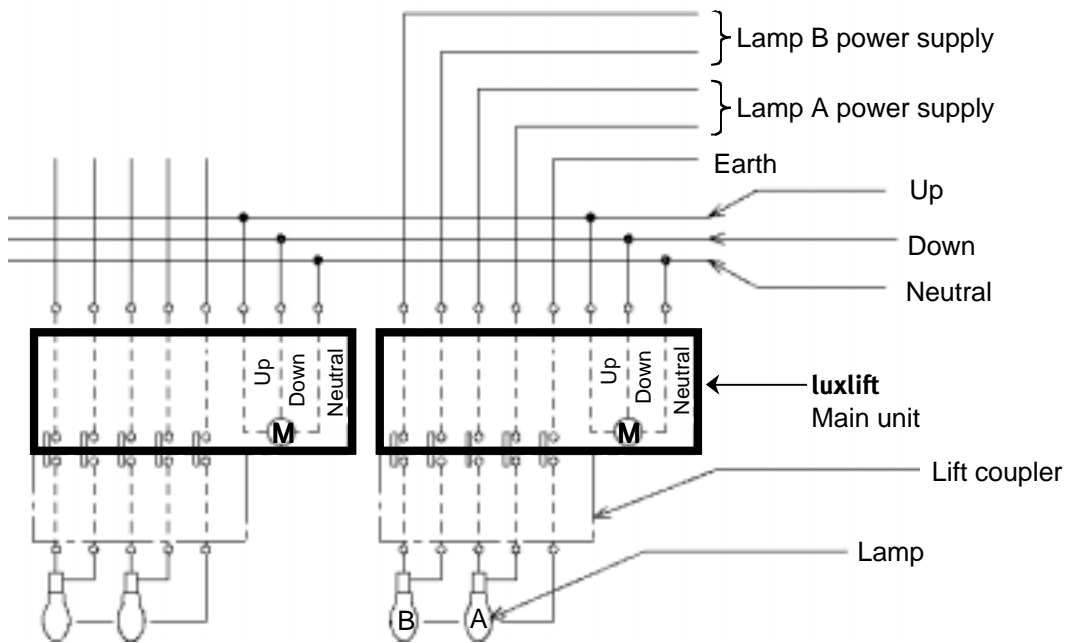

Connection of operating switch

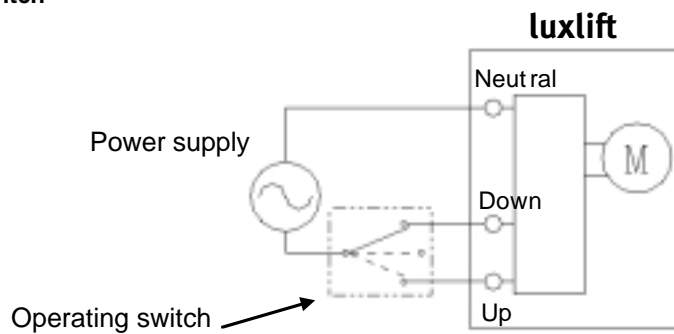

## OPTIONAL PARTS

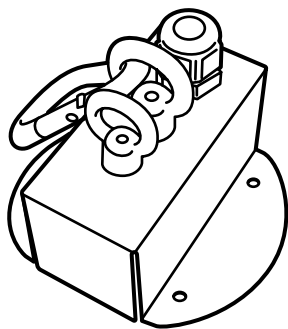

YKG31010, Adapter for luxlift Belt Drive 12kg type

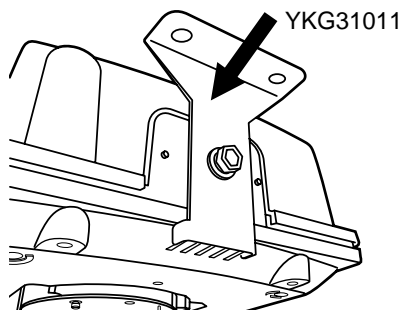

YKG31011, Flat angle bracket for luxlift 12kg type (2 pcs./set)

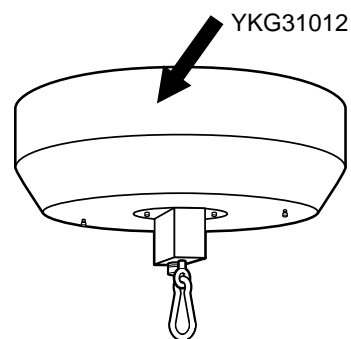

YKG31012, Cover for luxlift 12kg type

## NOTES

- This equipment is designed for indoor use only, not for outdoor nor in corrosive atmosphere.

## PACKING INFORMATION

| Type       | Q'ty | Dimensions            | Volume  | Net weight | Gross weight |
|------------|------|-----------------------|---------|------------|--------------|
| YBC08604   | 1pc. | 150mm x 358mm x 313mm | 0.017M3 | 5.9kg      | 7.6kg        |
| YBC0860420 |      |                       |         |            |              |

## Matsushita Electric Works

Please contact our Global Sales Companies in:



### Europe

|                  |   |   |
|------------------|---|---|
| ▶ Europe         | <b>Matsushita Electric Works (Europe) AG</b>      | Rudolf-Diesel-Ring 2, D-83607 Holzkirchen, Tel. (08024) 648-0, Fax (08024) 648-111, <a href="http://www.mew-europe.com">http://www.mew-europe.com</a>   |
| ▶ Austria        | <b>Matsushita Electric Works Austria GmbH</b>     | Stojanstraße 12, A-2344 Maria Enzersdorf, Tel. (0 22 36) 2 68 46, Fax (0 22 36) 4 61 33, <a href="http://www.matsushita.at">http://www.matsushita.at</a>                                      |
| ▶ Benelux        | <b>Matsushita Electric Works Benelux B.V.</b>     | De Rijn 4, (Postbus 211), 5684 PJ Best, (5680 AE Best), Netherlands, Tel. (0499) 372727, Fax (0499) 372185, <a href="http://www.matsushita.nl">http://www.matsushita.nl</a>                   |
| ▶ France         | <b>Matsushita Electric Works France S.A.R.L.</b>  | B.P. 44, F-91371 Verrières le Buisson CEDEX, Tél. 01 60135757, Fax 01 60135758, <a href="http://www.matsushita-france.fr">http://www.matsushita-france.fr</a>                                 |
| ▶ Germany        | <b>Matsushita Electric Works Deutschland GmbH</b> | Rudolf-Diesel-Ring 2, D-83607 Holzkirchen, Tel. (08024) 648-0, Fax (08024) 648-555, <a href="http://www.matsushita.de">http://www.matsushita.de</a>   |
| ▶ Ireland        | <b>Matsushita Electric Works UK Ltd.</b>          | Irish Branch Office, Waverley, Old Naas Road, Bluebell, Dublin 12, Republic of Ireland, Tel: (01) 4600969, Fax: (01) 4601131, <a href="http://www.luxlift.co.uk">http://www.luxlift.co.uk</a> |
| ▶ Italy          | <b>Matsushita Electric Works Italia s.r.l.</b>    | Via del Commercio 3-5 (Z.I. Ferlina), I-37012 Bussolengo (VR), Tel. (045) 6752711, Fax (045) 6700444, <a href="http://www.matsushita.it">http://www.matsushita.it</a>                         |
| ▶ Portugal       | <b>Matsushita Electric Works España S.A.</b>      | Portuguese Branch Office, Avda 25 de Abril, Edificio Alvorada 5ºE, 2750-512 Cascais, Portugal, Tel. (21) 4828266, Fax (21) 4827421  |
| ▶ Scandinavia    | <b>Matsushita Electric Works Scandinavia AB</b>   | Sjöängsvägen 10, 19272 Sollentuna, Sweden, Tel. (08) 59476680, Fax (08) 59476690  |
| ▶ Spain          | <b>Matsushita Electric Works España S.A.</b>      | Barajas Park, San Severo 20, E-28042 Madrid, Tel. (91) 3293875, Fax (91) 3292976  |
| ▶ Switzerland    | <b>Matsushita Electric Works Schweiz AG</b>       | Grundstrasse 8, CH-6343 Rotkreuz, Tel. (041) 7997050, Fax (041) 7997055, <a href="http://www.matsushita.ch">http://www.matsushita.ch</a>  |
| ▶ United Kingdom | <b>Matsushita Electric Works UK Ltd.</b>          | Sunrise Parkway, Linford Wood East, Milton Keynes, MK14 6LF, England, Tel. (01908) 231555, Fax (01908) 231599, <a href="http://www.luxlift.co.uk">http://www.luxlift.co.uk</a>                |

### North & South America

|       |   |  |
|-------|---|--|
| ▶ USA | <b>Aromat Corporation Head Office USA</b> | 629 Central Avenue, New Providence, N.J. 07974, Tel. 1-908-464-3550, Fax 1-908-464-8513, <a href="http://www.aromat.com">http://www.aromat.com</a> |
|-------|---|--|

### Asia

|             |   |  |
|-------------|---|--|
| ▶ China     | <b>Matsushita Electric Works Ltd. China Office</b>        | 2013, Beijing Fortune, Building No. 5, Dong San Huan Bei Lu, Chaoyang District, Beijing, Tel. 86-10-6590-8646, Fax 86-10-6590-8647                         |
| ▶ Hong Kong | <b>Matsushita Electric Works Ltd. Hong Kong</b>           | Rm1601, 16/F, Tower 2, The Gateway, 25 Canton Road, Tsimshatsui, Kowloon, Hong Kong, Tel. (852) 2956-3118, Fax (852) 2956-0398                             |
| ▶ Japan     | <b>Matsushita Electric Works Ltd.</b>                     | 1048 Kadoma, Kadoma-shi, Osaka 571-8686, Japan, Tel. 06-6908-1050, Fax 06-6908-5781, <a href="http://www.mew.co.jp/e-acg/">http://www.mew.co.jp/e-acg/</a> |
|             | <b>Automation Controls Group</b>                          |  |
| ▶ Singapore | <b>Matsushita Electric Works Pte. Ltd. (Asia Pacific)</b> | 101 Thompson Road, #25-03/05, United Square, Singapore 307591, Tel. (65) 255-5473, Fax (65) 253-5689   |