

Panasonic
ideas for life



Matsushita
PROFIBUS

PROFIBUS

Advantages

- With NAiS PROFIBUS DP and FMS, Matsushita offers the user a powerful program for communication at the intermediate and lower hierarchy levels.
- Certification ensures open communication between NAiS PROFIBUS units and PROFIBUS devices provided by other manufacturers. This is guaranteed by European Standard EN 50170.
- PROFIBUS is an established and well proven multi-purpose field bus worldwide, for plantwide use in all industries. Many leading automation companies use PROFIBUS technology.
- PROFIBUS is both fast and efficient. The modularity makes its use quick and reliable.
- A wide range of diagnostic options and error handling facilities is available.
- With PROFIBUS no additional costs are incurred for serial interface adapters for a range of different devices.

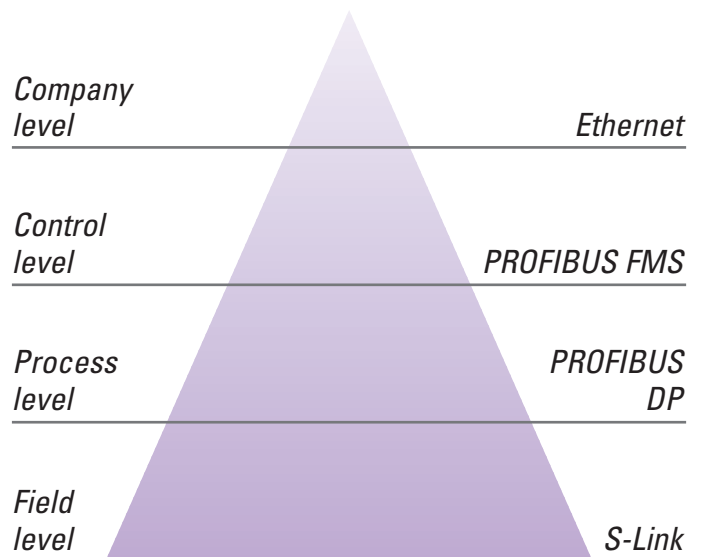

PROFIBUS FMS (Fieldbus Message Specification)

...is the solution optimized for cell level factory automation and multi-master applications, also for building automation. FMS offers comprehensive user services - known as FMS services - for writing and reading variables, starting and stopping programmes, events management and management services.

PROFIBUS DP (DECENTRAL PERIPHERY)

...is the most commonly used profile. It is a very robust system available for discrete manufacturing and process control because it offers substantial I/O capability, fast speed and long transmission distances. PROFIBUS DP has a decentralised I/O protocol arranged for cyclic data exchange.

Matsushita can supply a combined NAiS FMS / DP master.

PROFIBUS

Product Overview

FP2 FMS/DP Master Unit



FP2FMSDPM

PROFIBUS FMS/DP Expansion Unit for the FP2 Series PLCs
Ideal for extensive high-level multi-master networks.

Page 4

FP2 DP Master Unit



FP2DPM

PROFIBUS DP Master Expansion Unit for the FP2 Series PLCs
Ideal for cost-effective control of distributed field devices.

Page 5

FP0 DP Slave Unit



FP0DPS2

A DIP switch allows you to select between
PROFIBUS DP Slave or PROFIBUS remote I/O.

Page 6

The PROFIBUS DP Slave Unit connects
Matsushita's micro PLCs FP0 and FP Σ (Sigma)
to a PROFIBUS network as a slave.

PROFIBUS Remote I/O Unit



PROFIBUS Remote I/O Unit

connects I/Os at remote locations
via PROFIBUS.

Page 7-9

HMI PROFIBUS Interface Card



GK-IFC-PB

PROFIBUS DP Interface card for GK Series Key Terminals
allows cyclical and problem-free networking of numerous devices.

Page 10-11

Inverter PROFIBUS communication module



BFVC9901 and BFVC9902 PROFIBUS DP communication module

for the VF-CE Series Inverter connects Matsushita's VF-CE inverter
to a PROFIBUS network as a slave.

Page 12

PROFIBUS Accessories



9-pin SUB-D connectors

are used to connect stations to PROFIBUS.

Page 13

FP2 PROFIBUS

FMS / DP Master Unit

The FP2 FMS/DP master unit supports simultaneous operation of PROFIBUS FMS and DP.
This combined master unit operates at rates of up to 12 Mbaud.

FP2FMSDPM: FP2 FMS/DP Master Unit

Technical data

Type designation	FP2 FMS/DP Master Unit, Ord. No. FP2FMSDPM
PROFIBUS standards complied with	EN 50170, DIN 19245 Part 1, Part 2, Part 3
Baud rates	9.6 / 19.2 / 93.75 / 187.5 / 500 / 1,500 / 3,000 / 6,000 / 12,000 Kbaud
Number of open connections	64
Max. no. of PROFIBUS master units per CPU	1
Max. input/output data	238 Bytes / slave
PROFIBUS connection	9-Pin D-sub connector
Max. power consumption (5V)	500mA
Operating temperature range	0 ... 55°C
Storage temperature	-20 ... 70°C
Max. humidity	30% ... 85% (non-condensing)
Vibration resistance	10Hz to 55Hz, 1 cycle per minute with double amplitude 0.75mm; 10 min. per X, Y and Z axis
Shock resistance	min. 98m/s ² ; 4 times per X, Y and Z axis
Dimensions (mm)	28 x 100 x 90 (WxHxD)
Operating conditions	free from corrosive gases and excessive dust contamination
CE regulations	EMC Guideline 89/336/EEC 1989 - EN50081-2: 1993 - EN50082-2: 1995

FMS object and data types

Object types	Data types
Null Object	Integer 8
Data Type	Integer 16
Simple Variable	Integer 32
Array	Unsigned 8
OD-Object Description	Unsigned 16
	Unsigned 32
	Floating Point
	Octet String
	Visible String

Connection types

MMAZ	Master-master acyclic
MSAZ	Master-slave acyclic
MSZY	Master-slave cyclic
Multicast, Broadcast	

FMS services

Service	Controller class 3
Initiate	X
Abort	X
Status	X
Reject	X
Identify	S
Get OD	S
Initiate Put OD	S
Put OD	S
Terminate Put OD	S
Read	X
Write	X

X: Client and server
S: Server only

The data for Profibus DP mode are identical with FP2DPM.

FP2 PROFIBUS

DP Master Unit



FP2 PROFIBUS DP master unit links Matsushita's powerful FP2 controllers with a wide variety of distributed field devices. Designed for high-speed I/O communication, it is especially suited to time-critical applications.

The DP master unit allows the FP2 controller to communicate with the devices installed in the PROFIBUS network and to control slave devices. This unit supports baud rates of up to 12 Mbaud.

FP2DPM: FP2DP-Master Unit

Technical data

Type designation	FP2 DP Master Unit, Ord. No. FP2DPM
PROFIBUS standards complied with	EN 50170, DIN 19245 Part 1, Part 3
Baud rates	9.6 / 19.2 / 93.75 / 187.5 / 500 / 1,500 / 3,000 / 6,000 / 12,000 Kbaud
Max. no. of PROFIBUS slave units	125
Max. no. of PROFIBUS master units per CPU	1
Max. input/output data	238 bytes / slave
PROFIBUS services	The following PROFIBUS-DP master services are supported: Dat_Exchange, Slave_Diag, Set_Prm, Chk_Cfg, Global_Control (sync, freeze, clear), Get_Master_Diag, Start_Seq, Download, Upload, End_Seq, Act_Para_Brct
PROFIBUS connection	9-pin D-sub connector
Max. power consumption (5 V)	500mA
Operating temperature range	0 ... 55°C
Storage temperature	-20 ... 70°C
Max. humidity	30% ... 85% (non-condensing)
Vibration resistance	10Hz to 55Hz, 1 cycle per minute with double amplitude 0.75mm; 10 min. per X, Y and Z axis
Shock resistance	min. 98m/s ² ; 4 times per X, Y and Z axis
Dimensions (mm)	28 x 100 x 90 (WxHxD)
Operating conditions	free from corrosive gases and excessive dust contamination
CE regulations	EMC Guideline 89/336/EEC 1989 - EN50081-2 : 1993 - EN50082-2 : 1995

FP0 / FP Σ (Sigma) PROFIBUS

DP Slave Unit

The FP0 DP slave unit allows Matsushita's micro FP0 or FP Σ (Sigma) controller to be connected to PROFIBUS DP as a slave unit. The FP0 has its own powerful set of commands and operates independently.

In the PROFIBUS network the FP0 and FP Σ (Sigma) are intelligent remote slaves and can even continue the control function safely if fieldbus communication is interrupted.

A DIP switch allows the user to select between:

- FP0 DP Slave or (see below)
- PROFIBUS remote I/O unit (see next page)



Specifications of the FP0DPS2 unit in DP Slave mode

Technical data

Type designation	FP0 DP Slave unit, Ord. No. FP0DPS2
PROFIBUS standards complied with	EN 50170, DIN 19245 Part 1 and Part 3
Baud rates	9.6 / 19.2 / 93.75 / 187.5 / 500 / 1,500 / 3,000 / 6,000 / 12,000 Kbaud automatic baud rate detection
Range of addresses that can be set	0...125
PROFIBUS connection	9-pin D-sub connector
FP0 communication	Via FP0 system bus
Configuration	2 words input / 2 words output up to 6 words input/6 words output if no other expansion is connected
Power supply	24VDC (21.6VDC ... 26.4VDC)
Max. power consumption	100mA
Operating temperature range	0 ... 55°C
Storage temperature	-20 ... 70°C
Max. humidity	30% ... 85% (non-condensing)
Vibration resistance	10Hz to 55Hz, 1 cycle per minute with double amplitude 0.75mm; 10 min.per X , Y and Z axis
Shock resistance	min. 98m/s ² ; 4 times per X, Y and Z axis
Dimensions (mm)	25 x 90 x 60 (WxHxD)
Operating conditions	free from corrosive gases and excessive dust contamination
CE regulations	EMC Guideline 89/336/EEC 1989 - EN50081-2 : 1993 - EN50082-2 : 1995

FP0 / FP Σ (Sigma) PROFIBUS

Remote I/O Unit

The PROFIBUS remote I/O unit directly connects distributed I/Os to the PROFIBUS network.

Locating I/Os near to sensors and actuators reduces wiring costs and complexity.

Up to 3 FP0 expansion units can be connected to the FP0DPS2 unit. A full range of digital and analogue I/Os are available to meet all your application needs.

The FP0DPS2 unit can also be connected to any PLC which offers a PROFIBUS communication interface, making it totally independent of NAI's PLCs.

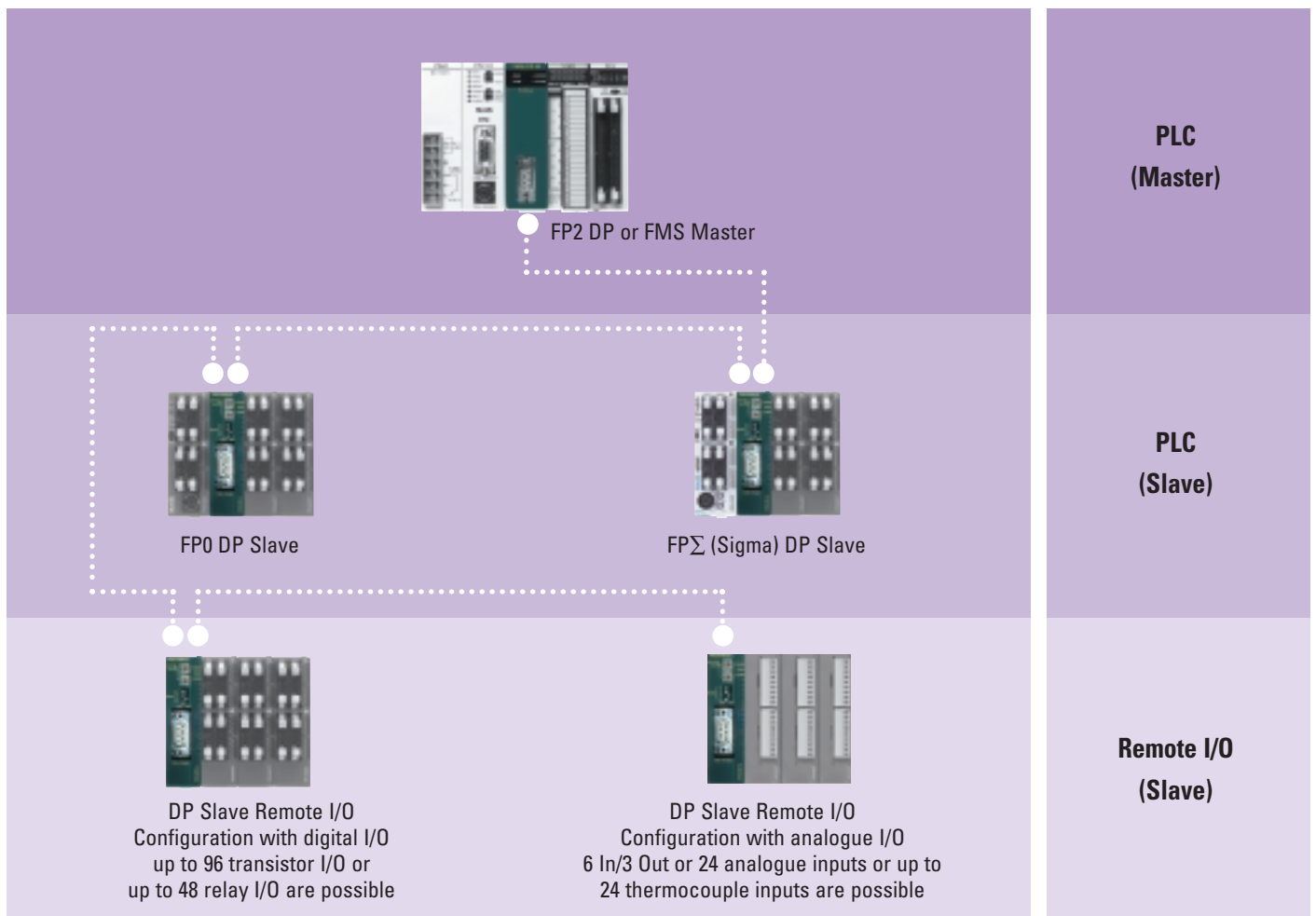

PROFIBUS Remote I/O Unit

A maximum of 3 expansion units can be added

Digital I/O Units

Relay output type



8 points
Input 4 points Output 4 points
Terminal type

Option:
Output 8 points



16 points
Input 8 points Output 8 points
Terminal type

Input only type



8 points
Input 8 points



16 points
Input 16 points

Transistor output type



8 points
Input 8 points
NPN output type
PNP output type



16 points
Input 8 points Output 8 points
NPN output type
PNP output type



16 points
Output 16 points
NPN output type
PNP output type



32 points
Input 16 points Output 16 points
NPN output type
PNP output type

Analogue I/O Units



3 points
Input 2 points Output 1 point
Terminal type

- analogue input: $\pm 10V, 0 - 5V, 0 - 20mA$
- analogue output: $\pm 10V, 0 - 20mA$
- resolution: 12 bits



8 points
Input 8 points
Terminal type

- analogue input: $\pm 10V, \pm 100mV, 0 - 5V, 0 - 20mA$
- resolution: 12 bits

Thermocouple Units



4 points
Input 4 points

- K, J, T, R type thermocouples can be used
- Resolution: 0.1 °C
- Accuracy: 0.8 °C (R type: 3 °C)
- Temperature range: -100 to 500 °C



8 points
Input 8 points

AC Power Supply

FP0-PSA2



Input 85 to 265VAC Output 24DC/0.7A
Terminal type

Easy Expansion

The expansion unit can be attached easily without any cables.

Up to 3 expansion units can be connected to the PROFIBUS remote I/O unit. Special expansion cables, backplanes, and so forth, are unnecessary as the expansion unit employs a stacking system that uses expansion connectors and lock levers on the surface of the unit itself.

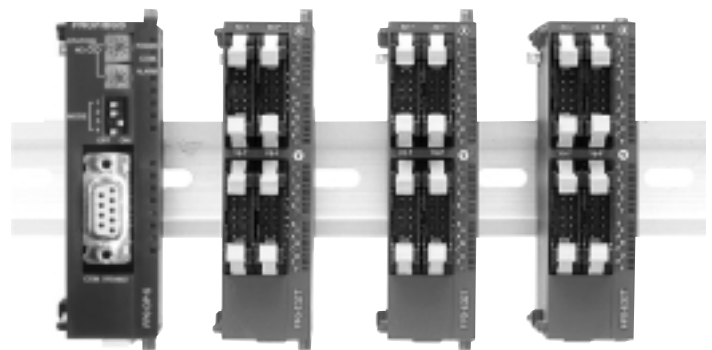

FP0 DPS2 ◀ Expansion unit ◀ Expansion unit ◀ Expansion unit

(Maximum possible expansion is three units)

PROFIBUS Remote I/O Unit

Specifications

Specifications of the FP0DPS2 unit in remote I/O mode

Type designation	FP0DPS2
PROFIBUS standards complied with	EN 50170, DIN 19245 Part 1 and Part 3
Baud rates	9.6 / 19.2 / 93.75 / 187.5 / 500 / 1,500 / 3,000 / 6,000 / 12,000 Kbaud automatic baud rate detection
Range of addresses that can be set	0...125
PROFIBUS connection	9-pin D-sub connector
Configuration	Remote I/O, max. 3 FP0 Expansion Units
Power supply	24 VDC (21.6 VDC ... 26.4 VDC)
Max. power consumption	100 mA
Operating temperature range	0 ... 55 °C
Storage temperature	-20 ... 70°C
Max. humidity	30% ... 85% (non-condensing)
Vibration resistance	10Hz to 55Hz, 1 cycle per minute with double amplitude 0.75mm; 10 min.per X , Y and Z axis
Shock resistance	min. 98m/s ² ; 4 times per X, Y and Z axis
Dimensions (mm)	25 x 90 x 60 (WxHxD)
Operating conditions	free from corrosive gases and excessive dust contamination
CE regulations	EMC Guideline 89/336/EEC 1989 - EN50081-2 : 1993 - EN50082-2 : 1995



HMI PROFIBUS

PROFIBUS Interface Card for GK Operator Terminals

The GK terminals can be upgraded with additional expansion cards, which is why the GK30 and GK60 terminals have one and the GK70 and GK90 terminals two further plug-in facilities for expansion cards. This allows the terminals to communicate via PROFIBUS.



GK90
640 x 480 pixels



GK70
320 x 240 pixels

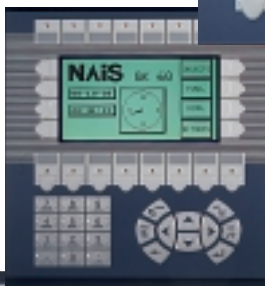

GK60
240 x 128 pixels



GK30
240 x 64 pixels

The GK-IFC-PB expansion card allows cyclical and problem-free networking of numerous devices. With a transmission rate of 12Mbit/s, data can be exchanged between as many as 32 users (without a repeater) or 96 users (with a repeater) over a two-wire link.



HMI PROFIBUS

PROFIBUS Interface Card for GK Operator Terminals

Technical Specifications

Part Number	GK-IFC-PB
Power consumption	internal via GK terminals
Transmission rate	9.6 / 19.2 / 93.75 / 187.5 / 500kBit/s; 1.5 / 3 / 6 / 12Mbit/s automatic baud rate detection
Protocol	PROFIBUS DP
Data transfer	200 bytes when transmitting and receiving
Field bus standard	EN50170 volume 2
Max. number of nodes without repeater	32
Max. nodes with repeater	96
Max. cable length with repeater	3,000m / 9.6kbits
Max. cable length without repeater	200m / 12Mbits
Connection type	D-Sub and screw connections
Termination	DIP switch
Ambient temperature	0 to + 70°C
Storage temperature	-20 to +70°C
Ambient humidity	30 to 85% RH (non-condensing)
Storage humidity	30 to 95% RH (non-condensing)
Insulation resistance	100MΩ or more between external terminals and GND
Vibration resistance	corresponds to IEC 68-2-6 (test Fc.) and IEC 68-2-64 (test Fh.)
Shock resistance	10g, 4 x on 3 axes
EMC	EN50081-2 and EN50082-2
Weight	0.3kg

Installing the expansion cards

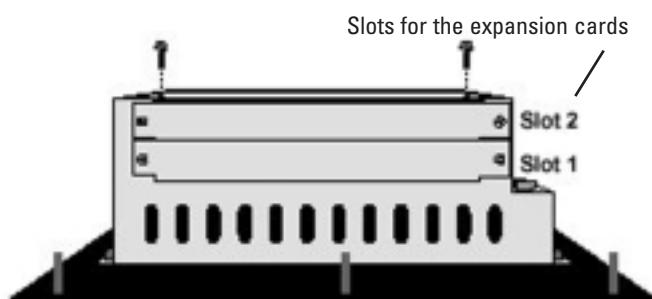

e. g. GK70

There are 1 or 2 slots for the expansion cards on the back of the GK terminals.

GK30 / GK60: 1 slot

GK70 / GK90: 2 slots

Card in slot 2

Card in slot 1

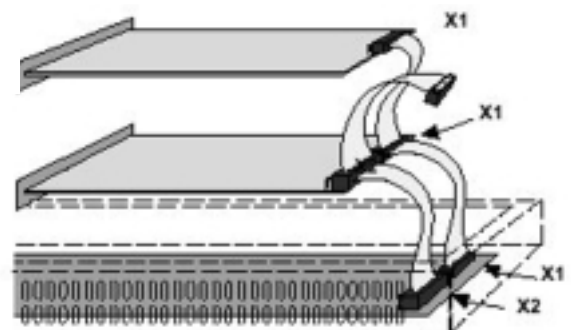

The expansion cards are connected to the CPU of the terminal via a parallel interface.

Inverter PROFIBUS

PROFIBUS Interface Modules for VF-CE Inverter

For the 0.25kW to 4.0kW power range

- Ultra-compact
- Integrated filter with EMC interference to class B
- Vector control and V/f control
- Up to $1.8 \times M_N$ torque for 60s (M_N = rated load torque)
- Multiple interfaces (digital/analogue - I/O, RS232/RS485, PROFIBUS)
- Operator module with copy function
- International approvals (CE, UL, cUL)
- Cost effective
- Energy efficient
- Types: 1-phase 230VAC: 0.25 to 2.2kW
(1-phase 115VAC: 0.12 to 0.18kW)
3-phase 400VAC: 0.75 to 4.0kW
(3-phase 200VAC: 0.75 to 2.2kW)

The VF-CE inverter has 2 user interfaces:

- AIF: Communications interface
- FIF: Standard interface

Standard I/O module in the FIF:

- Integrated digital/analogue I/O
- PROFIBUS as an alternative



PROFIBUS interface FIF
BFVC9902

System unit



Communication modules in the AIF:

- Operator module
- RS232 / RS485
- PROFIBUS



PROFIBUS
interface AIF
BFVC9901

The PROFIBUS modules

Two different PROFIBUS modules permit open communication in accordance with the international EN50170 standard. The PROFIBUS FIF module is used instead of the standard I/O module. If the standard I/O module is necessary in the application, the PROFIBUS AIF module can be used as the automation interface.

- Bit rate: 9.6 kBaud ... 12 MBaud (automatic detection)
- Max. cable length: 1.2km (depends on baud rate and cable)
- Number of stations: 32 (with repeater 125)
- PROFIBUS status: Slave
- Communication profile: PROFIBUS-DP (DIN 19245, parts 1 and 3)
- Drive profile: DRIVECOM Profile 20
- Access to all parameters



PROFIBUS Accessories

Connectors and Cables

9-pin SUB-D Connector

These 9-pin Sub-D connectors are used to connect stations to the PROFIBUS. The cables can be connected either horizontally or vertically. To clearly identify whether the connection involved is a bus node or a bus termination two versions are offered, which also differ in colour:

- Bus node version without terminating resistor : slate gray
- Bus termination version with terminating resistor : yellow

There is a second version of the bus node with a service connector which is used for connecting the programming interface or for diagnostic purposes.



Vertical node („0°“ type)



Horizontal node („90°“ type)

Technical data

Type designation	Horizontal node (90°) without terminating resistor, Vertical node (0°) without terminating resistor, Horizontal node (90°) with terminating resistor, Vertical node (0°) with terminating resistor, Horizontal node (90°) with service connector	Ord. No. PR 103-648 Ord. No. PR 103-658 Ord. No. PR 103-649 Ord. No. PR 103-659 Ord. No. PR 103-663
Baud rate	up to 12 Mbaud	
Operating temperature ranges	-20 to + 70°C	
Permissible humidity	max. 75% at + 25°C	
Protection class	IP 40	
Dimensions	64.6 x 47.5 x 16	
Casing material	Thermoplastic UL 94 V-1	
Optional EMI/RFI protection through internal screening		
ESD protection to IEC 801-2		

PROFIBUS Cable

PR2170220T: Standard cable for internal wiring

Solid, bare Cu conductor, two wires twisted, screened with plastic-coated aluminium foil and braid of bare Cu wires. Outer cover made of special PVC-based mixture, flame-resistant, colour violet (RAL 4001)

This cable should be used for setting up a PROFIBUS network. The maximum cable length in such cases is dependent on the baud rate.



Baud rate (Kbaud)	9.6	19.2	93.75	187.5	500	1,500	12,000
Max. bus length	1,200 m	1,200 m	1,200 m	1,000 m	400 m	200 m	100 m

PROFIBUS Configurator

Configuration software for PROFIBUS FMS

Devices from different suppliers can be connected to the PROFIBUS. The configurator software is needed to set the parameters in the PROFIBUS network in order that these devices can communicate with each other.

PROFIBUS FMS Configurator

The FMS configurator software allows user-friendly configuration of a PROFIBUS FMS network. This software supplies the necessary parameters for an individual network.

The editors of the FMS configurator support the following functionalities:

- Device functionality
- Network topology
- Logical device connections: Communication links
- Communication objects
- Object directories
- Bus parameters

To configure the PROFIBUS you will need the PROFIBOARD which connects the PC to PROFIBUS in your computer.



PROFIBUS Tool

The PROFIBUS TOOL is delivered with the FMS Configurator and is used to:

1. set the:

- COM port of the PC which is connected to the PLC
- baud rate for data transfer between PC and PLC
- connected PLC type
- baud rate of the PROFIBUS unit
- PROFIBUS address and
- slot no. of the PROFIBUS unit

2. convert the CNF file (configuration file) which is provided by the configurator into a List of Global Variables (ASC file)
You can import the ASC file into you PLC program in order to make variables available for the PLC program in NAiS Control



PROFIBUS Configurator

Configuration software for PROFIBUS DP

PROFIBUS DP Configurator

The DP configurator software:

- imports third-party provided device descriptions as DDB files (in Germany usually referred as GSD) to add to the device description database, remove and update DDB files in the device description database
- creates and edits configuration projects by adding, changing and deleting device descriptions for the master and the slaves
- configures bus parameters
- configures modular slaves by adding or deleting slot definitions assign station addresses
- assigns stations to groups, changes operation modes, and edits watchdog timeouts for stations
- creates master parameter set as binary file for download later by another master application
- downloads the master parameters set to a remote DP master

PROFIBUS Tool

The PROFIBUS TOOL is delivered with the DP Configurator and is used to:

- download BUS parameter data to the PROFIBUS unit via the TOOL port of the PLC
- download slave configuration data to the PROFIBUS unit via the TOOL port of the PLC
- convert the CNF file (configuration file) which is provided by the configurator into a List of Global Variables (ASC file)
- import the ASC file into your PLC program in order to make variables available for the PLC program in NAiS Control FPWIN Pro





North America	Europe	Asia Pacific	China	Japan
Aromat Corporation	Matsushita Electric Works	Matsushita Electric Works	Matsushita Electric Works	Matsushita Electric Works, Ltd. Automation Controls Group

Matsushita Electric Works

Please contact our Global Sales Companies in:

Europe		
▶ Europe	Matsushita Electric Works (Europe) AG	Rudolf-Diesel-Ring 2, D-83607 Holzkirchen, Tel. (08024) 648-0, Fax (08024) 648-111, www.mew-europe.com
▶ Austria	Matsushita Electric Works Austria GmbH	Josef Madersperger Straße 2, A-2362 Biedermannsdorf, Tel. (02236) 26846, Fax (02236) 46133, www.matsushita.at
▶ Benelux	Matsushita Electric Works Benelux B.V.	De Rijn 4, (Postbus 211), 5684 PJ Best, (5680 AE Best), Netherlands, Tel. (0499) 372727, Fax (0499) 372185, www.matsushita.nl or www.matsushita.be
▶ France	Matsushita Electric Works France S.A.R.L.	B.P. 44, F-91371 Verrières le Buisson CEDEX, Tél. 01 60135757, Fax 01 60135758, www.matsushita-france.fr
▶ Germany	Matsushita Electric Works Deutschland GmbH	Rudolf-Diesel-Ring 2, D-83607 Holzkirchen, Tel. (08024) 648-0, Fax (08024) 648-555, www.matsushita.de
▶ Ireland	Matsushita Electric Works UK Ltd.	Irish Branch Office, Waverley, Old Naas Road, Bluebell, Dublin 12, Republic of Ireland, Tel: (01) 4600969, Fax: (01) 4601131, www.matsushita.ie
▶ Italy	Matsushita Electric Works Italia s.r.l.	Via del Commercio 3-5 (Z.I. Ferlina), I-37012 Bussolengo (VR), Tel. (045) 6752711, Fax (045) 6700444, www.matsushita.it
▶ Portugal	Matsushita Electric Works España S.A.	Portuguese Branch Office, Avda 25 de Abril, Edificio Alvorada 5ºE, 2750-512 Cascais, Portugal, Tel. (21) 4828266, Fax (21) 4827421
▶ Scandinavia	Matsushita Electric Works Scandinavia AB	Sjöängsvägen 10, 19272 Sollentuna, Sweden, Tel. (08) 59476680, Fax (08) 59476690, www.matsushita.se
▶ Spain	Matsushita Electric Works España S.A.	Parque Empresarial Barajas, San Severo 20, 28042 Madrid, Tel. (91) 3293875, Fax (91) 3292976, www.matsushita.es
▶ Switzerland	Matsushita Electric Works Schweiz AG	Grundstrasse 8, CH-6343 Rotkreuz, Tel. (041) 7997050, Fax (041) 7997055, www.matsushita.ch
▶ United Kingdom	Matsushita Electric Works UK Ltd.	Sunrise Parkway, Linford Wood East, Milton Keynes, MK14 6LF, England, Tel. (01908) 231555, Fax (01908) 231599, www.matsushita.co.uk
North & South America		
▶ USA	Aromat Corporation Head Office USA	629 Central Avenue, New Providence, N.J. 07974, Tel. 1-908-464-3550, Fax 1-908-464-8513, www.aromat.com
Asia		
▶ China	Matsushita Electric Works Ltd. China Office	2013, Beijing Fortune, Building No. 5, Dong San Huan Bei Lu, Chaoyang District, Beijing, Tel. 86-10-6590-8646, Fax 86-10-6590-8647
▶ Hong Kong	Matsushita Electric Works Ltd. Hong Kong	Rm1601, 16/F, Tower 2, The Gateway, 25 Canton Road, Tsimshatsui, Kowloon, Hong Kong, Tel. (852) 2956-3118, Fax (852) 2956-0398
▶ Japan	Matsushita Electric Works Ltd.	1048 Kadoma, Kadoma-shi, Osaka 571-8686, Japan, Tel. 06-6908-1050, Fax 06-6908-5781, www.mew.co.jp/e-acg/
▶ Singapore	Matsushita Electric Works (Asia Pacific) Pte. Ltd.	101 Thomson Road, #25-03/05, United Square, Singapore 307591, Tel. (65) 6255-5473, Fax (65) 6253-5689