

LA SERIES

Laser Collimated Beam Sensor

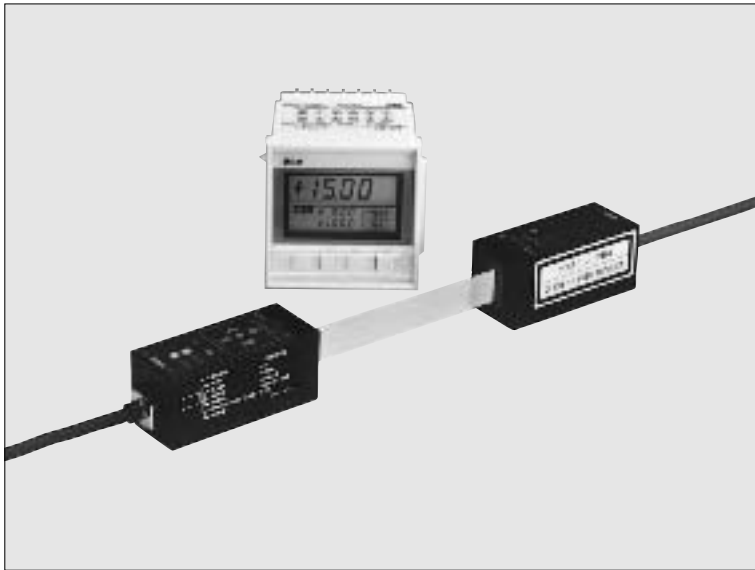

'Class 1' Laser Beam Sensor Safe for Your Eyes

CE Marked
Conforming to EMC Directive
(Excluding LA-C1)

Safe Laser Beam

This laser collimated beam sensor conforms to the Class 1 laser stipulated in IEC Publication 825 and JIS C 6802. Hence, safety measures such as protective gear are not necessary.

Precise Sensing in Wide Area

Sensing area: $15 \times 500\text{mm}$
Minimum sensing object: $\phi 0.1\text{mm}$
Repeatability: $10\mu\text{m}$ or less

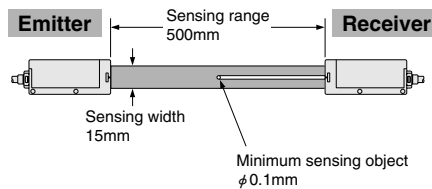

Easy Laser Beam Alignment

Four monitoring LEDs help you to easily align the emitter and the receiver.

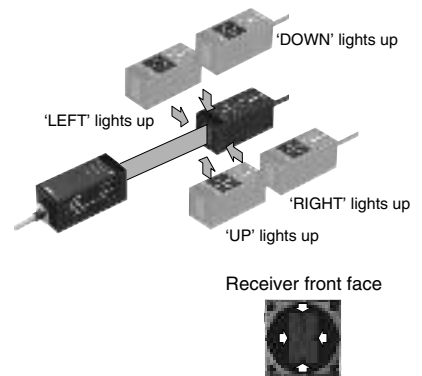

Versatile Mounting

The side view attachment (optional) enables versatile mounting styles.

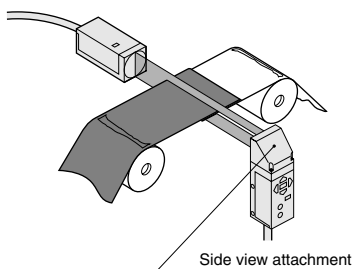

FDA Class 1 Type LA-511

LA-511 conforms to FDA Class 1. It is approved for use in U.S.A. by FDA.

The monitoring system checks whether the incident beam falls evenly on all the four receiving elements in the receiver window.

APPLICATIONS

Accurate positioning of orientation flat

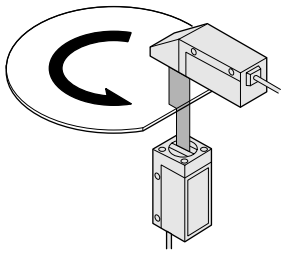

Detecting cathode ray tube

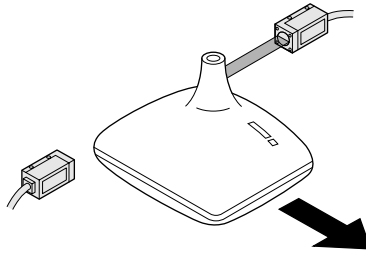

Detecting tablet displaced from pocket

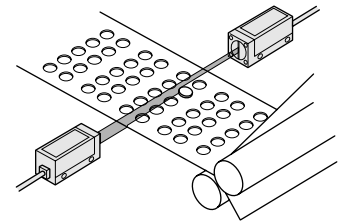

Counting number of O-rings

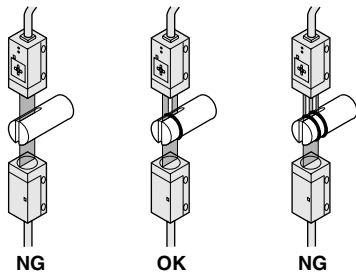

Positioning gear on polishing machine

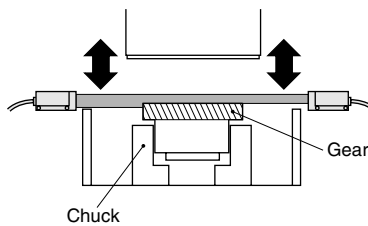

Attitude of chip component

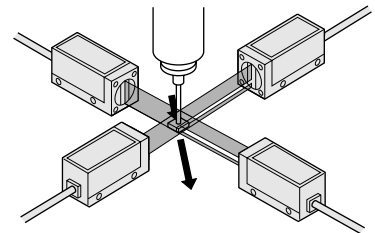

Convenient Laser Sensor Controller LA-C1

Simple digital setting

Fine adjustment can be easily done using the actual object while observing the digital display.

Large 3 1/2 digit display

Easily visible 10mm letter height display.

Auto-reference function

The set values can be automatically compensated for a change in the reference value by using an external signal.

Two types of operation modes

- ① Hysteresis mode
- ② Window comparator mode



Operation theory

- The semiconductor laser diode and an advanced optical system realize an ideal collimated beam.

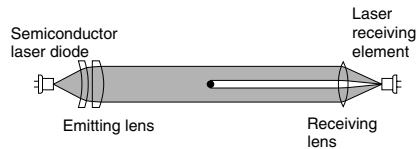

- The high precision APC circuit maintains constant laser beam output power.

The APC (Automatic Power Control) circuit maintains stable emission strength by a feedback technique. A uniform emission level is maintained inspite of temperature drift and/or supply voltage change.

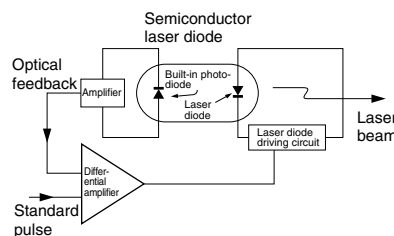

High accuracy applications

- The sensor can be used for various applications due to its collimated laser beam.

Positioning

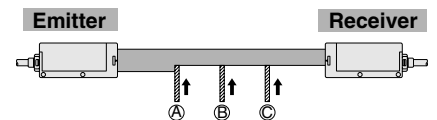

Detection at same degree of intrusion at any position ((A), (B) or (C)) within the sensing range.

Presence detection

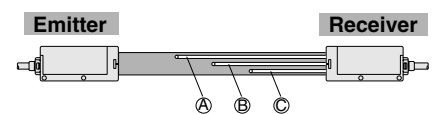

The path position of the sensing object need not be fixed.

Width discrimination

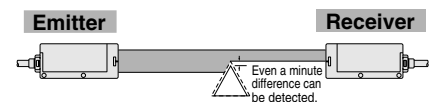

Even a minute difference can be reliably detected since the difference in the beam interruption is projected, as it is, on the receiving section.

Detecting amount of laser beam



Its wide laser beam senses the total object.

ORDER GUIDE

Laser collimated beam sensors

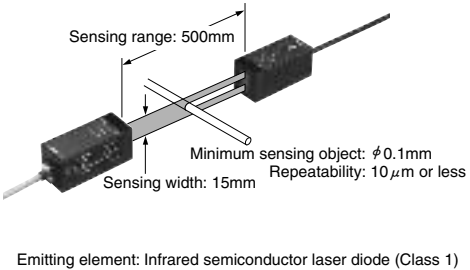
Type	Appearance	Model No.	Conforming standard
Class 1 type	 <p>Sensing range: 500mm</p> <p>Minimum sensing object: ϕ0.1mm</p> <p>Repeatability: 10 μm or less</p> <p>Sensing width: 15mm</p> <p>Emitting element: Infrared semiconductor laser diode (Class 1)</p>	LA-510	IEC and JIS standards
		LA-511	FDA standard

Laser sensor controller

Appearance	Model No.
 <p>DIN 72 × 72mm</p>	LA-C1

OPTIONS

Designation	Model No.	Description
Side view attachment	LA-SV1	Versatile mounting is possible as the laser beam can be bent at a right angle. <ul style="list-style-type: none"> • Sensing range: 500mm • Minimum sensing object: ϕ0.1mm • Repeatability: 20 μm or less (Note 1)
Digital panel controller	CA2-T2	NPN open-collector transistor <ul style="list-style-type: none"> • This is a very small controller which allows two independent threshold level settings. • Supply voltage: 24V DC \pm 10% • No. of inputs: 1 No. (sensor input) • Input range: 1 to 5V DC • Main functions: Threshold level setting function, zero-adjust function, scale setting function, hysteresis setting function, start/hold function, auto-reference function, power supply ON-delay function, etc.

Side view attachment

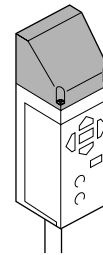

Two M3 (length 10mm) screws with washers are attached.

Digital panel controller

• CA2 series



Notes :1) Mount **LA-SV1** on either the emitter or the receiver. If it is mounted on both sides, the monitor LEDs may not light off perfectly.

SPECIFICATIONS

Laser collimated beam sensors

Item	Type Conforming standard Model No.	Class 1 type	
		IEC and JIS standards LA-510	FDA standard LA-511
Sensing width		15mm	
Sensing range		500mm	
Min. sensing object		φ 0.1mm opaque object	
Repeatability		10 μm or less	
Supply voltage		12 to 24V DC ± 10% Ripple P-P 10% or less	
Current consumption		Emitter: 35mA or less, Receiver: 25mA or less	
Comparative output		NPN open-collector transistor • Maximum sink current: 100mA • Applied voltage: 30V DC or less (between comparative output and 0V) • Residual voltage: 1V or less (at 100mA sink current) 0.4V or less (at 16mA sink current)	
	Utilization category	DC-12 or DC-13	
	Response time	0.5ms or less	
	Output operation	ON when the incident beam amount is less than the threshold level	
	Short-circuit protection	Incorporated	
Analog output		Analog voltage • Output voltage: 1V (Darkest) to 5V (Lightest) • Output impedance: 75Ω	
	Slew rate	8V/ms or more	
	Temperature characteristics	Within ± 0.1% F.S./°C (with respect to sensing range at ambient temperature + 20°C)	
Remote interlock input		Laser is emitted when it is connected to 0V, but not emitted when connected to + V or kept open	
Indicators	Operation	Red LED (lights up when the comparative output is ON)	
	Laser emission warning	Red LED (lights up when laser is being emitted)	
	Stable incident beam	Green LED (lights up under the stable light received condition)	
	Laser beam alignment	Yellow LED × 4 (light up when laser beam is misaligned)	
Adjusters	Threshold level	Adjustment of threshold level for the comparative output, 18-turn endless adjuster	
	Span	Adjustment of span for the analog voltage output, 18-turn endless adjuster	
Environmental resistance	Pollution degree	3 (Industrial environment)	
	Ambient temperature	0 to + 50°C (No dew condensation), Storage: - 20 to + 70°C	
	Ambient humidity	35 to 85% RH, Storage: 35 to 85% RH	
	Ambient illuminance	Sunlight: 10,000 lx at the light-receiving face, Incandescent light: 10,000 lx at the light-receiving face	
	EMC	Emission: EN50081-2, Immunity: EN50082-2	
	Insulation resistance	20MΩ, or more, with 250V DC megger between all supply terminals connected together and enclosure	
	Vibration resistance	10 to 55Hz frequency, 1.5mm amplitude in X, Y and Z directions for two hours each	
Shock resistance	500m/s ² acceleration (50G approx.) in X, Y and Z directions for three times each		
Emitting element		Infrared semiconductor laser diode (Maximum output: 1.7mW, Peak emission wavelength: 780nm)	
Enclosure earthing		Capacitor earth	
Material		Enclosure: Die-cast zinc alloy, Top cover: PPO, Front protection cover: Glass	
Cable		0.2mm ² 5-core (emitter: 4-core) shielded cable, 3m long	
Cable extension		Extension up to total 50m is possible, for both emitter and receiver, with 0.3mm ² , or more, cable. (Synchronization wire cannot be extended.)	
Weight		Emitter: 290g approx., Receiver: 280g approx.	
Accessories		MS-LA1 (Sensor mounting bracket): 2 sets Adjusting screwdriver: 1 No. Crimp contact: 2 Nos. Class 1 identification label: 1 No. (LA-510 only) Inspection slip: 1 No. (LA-511 only)	

SPECIFICATIONS

Laser sensor controller

Model No.		LA-C1
Item		
Supply voltage		12 to 24V DC \pm 10% Ripple P-P 10% or less
Current consumption		260mA or less
Power supply for sensor		12V DC, 70mA max.
Input	Sensor input	Input voltage range: 1 to 5V (Maximum allowable voltage: 10V DC) Input impedance: 1M Ω A/D conversion method: double integration method Sampling cycle: 50ms (20 times/sec.)
	Auto-reference input	Specifying timing of auto-reference function • Operation: Effective when NPN non-contact transistor input is Low • Signal condition: Low level 1.5V or less Low level output current 0.6mA or less Low level input time duration 0.5ms or more
Output	Comparative output	NPN open-collector transistor (3 outputs of HI, GO or LO) • Maximum sink current: 100mA • Applied voltage: 30V DC or less (between comparative output and 0V) • Residual voltage: 1V or less (at 100mA sink current) 0.4V or less (at 16mA sink current)
	Output operation	<div style="display: flex; justify-content: space-around;"> <div style="text-align: center;"> <p>Hysteresis mode</p> <p>(Normally in OFF state)</p> <p>Minimum ← Measurement value → Maximum</p> </div> <div style="text-align: center;"> <p>Window comparator mode</p> <p>Minimum ← Measurement value → Maximum</p> </div> </div>
	Response time	100ms or less (150ms or less while the auto-reference input is applied)
	Short-circuit protection	Incorporated
Display	Measurement value display	3 1/2 digit LCD display [Display cycle: 250ms (4 times/sec.)]
	Display range	- 19.99 to + 19.99
	Accuracy	\pm (0.15% \times Measurement value + 1 digit) at 23 \pm 1°C
	Setting value display	3 1/2 digit LCD display
Display range	- 19.99 to + 19.99	
Comparative output operation display	LCD display of 'HI', 'GO' and 'LO' (HI, GO or LO lights up when the respective output is ON)	
Environmental resistance	Ambient temperature	0 to + 50°C (No dew condensation), Storage: - 10 to + 60°C
	Ambient humidity	35 to 85% RH, Storage: 35 to 85% RH
	Noise immunity	Power line: 240Vp, 10ms cycle, and 0.5 μ s pulse width Radiation: 300Vp, 10ms cycle, and 0.5 μ s pulse width (with noise simulator)
	Vibration resistance	10 to 55Hz frequency, 1mm amplitude in X, Y and Z directions for two hours each
	Shock resistance	300m/s ² acceleration (30G approx.) in X, Y and Z directions for three times each
Connection method	Screw-on terminal block	
Material	Enclosure: Polycarbonate, Front bezel: ABS, Terminal block: PBT, Front panel: Acrylic, Protector: Acrylic	
Weight	230g approx.	

I/O CIRCUIT AND WIRING DIAGRAMS

Laser collimated beam sensor

I/O circuit diagram

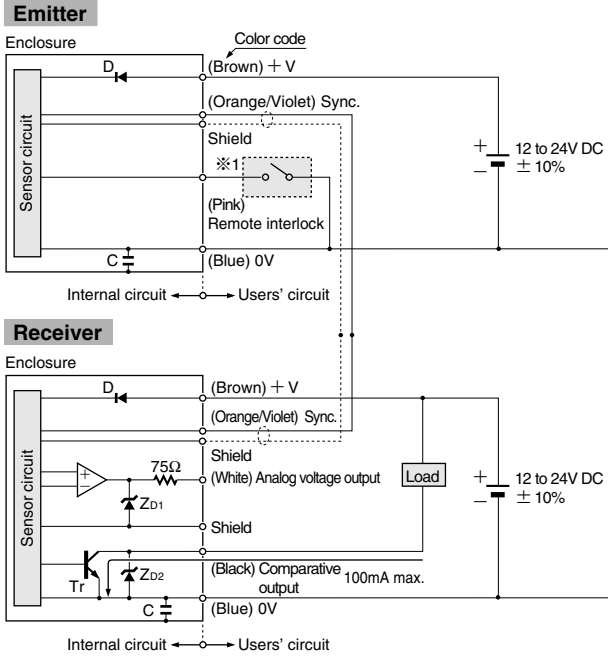

Symbols ... D: Reverse supply polarity protection diode
 Z_{D1}, Z_{D2}: Surge absorption zener diode
 C: Capacitor (0.022 μF)
 Tr: NPN output transistor

Wiring diagram

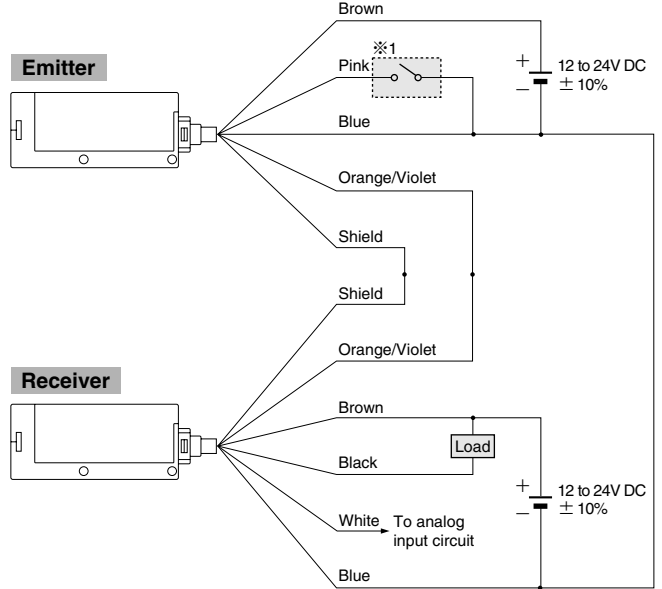

※1

Laser emission: connection to 0V
 Laser emission stop: connection to +V, or open

Laser sensor controller

I/O circuit diagram

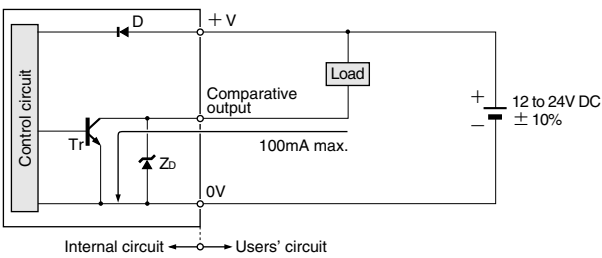

Symbols ... D: Reverse supply polarity protection diode
 Z_D: Surge absorption zener diode
 Tr: NPN output transistor

Auto-reference input circuit diagram

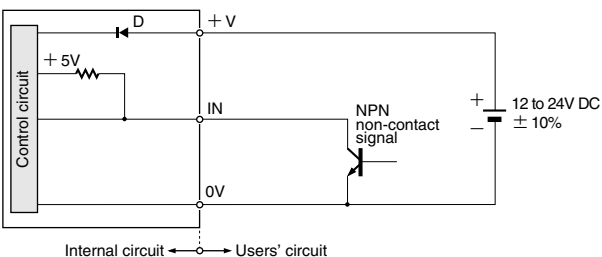

Symbol ... D: Reverse supply polarity protection diode

Wiring diagram

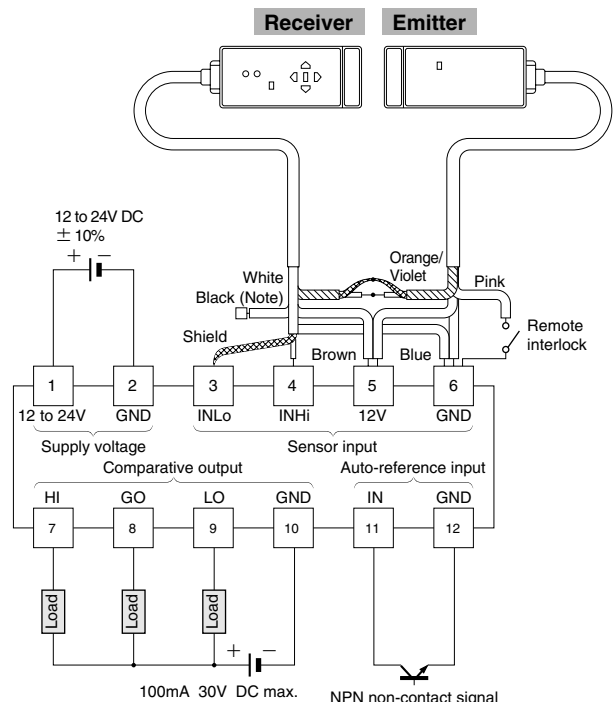

Note: In case the receiver's comparative output wire (black) is not used, please insulate it.

SENSING CHARACTERISTICS (TYPICAL)

Correlation between setting distance and excess gain

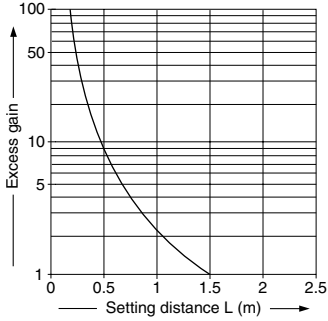

Correlation between transverse deviation and output voltage

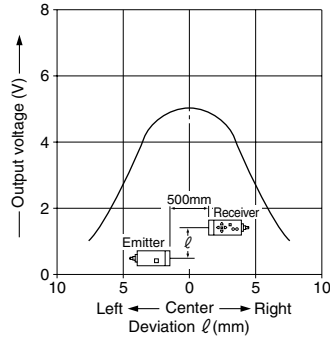

Correlation between interrupted beam width and output voltage

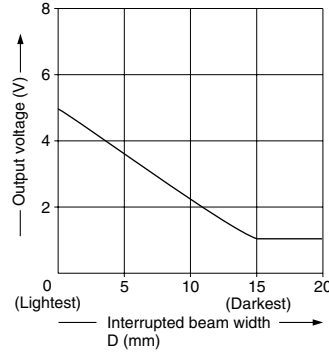

Correlation between ambient temperature and output voltage variation rate

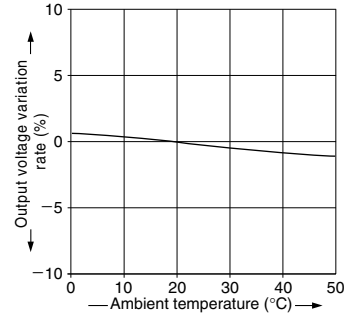

PRECAUTIONS FOR PROPER USE

Laser collimated beam sensor



This product is not a safety sensor. Its use is not intended or designed to protect life and prevent body injury or property damage from dangerous parts of machinery. It is a normal object detection sensor.



Safety measures for laser beam products

- The safety standard IEC Publication 825 specifies the application of laser beam products. Please read it carefully before using the laser beam sensor.
- Do not expose your eyes to the laser beam through optical instruments, like a lens.

Safety standards for laser beam products

- A laser beam can harm human being's eyes, skin, etc., because of its high energy density. IEC and JIS have classified laser products according to the degree of hazard and the stipulated safety requirements.

LA-510 and LA-511 are identified as a 'Class 1' laser products.

Class	Applicable model No.	Degree of danger
Class 1	LA-510 LA-511	Intrinsically safe design.
Class 2	—	Visible and low power (wavelength 400 to 700nm). Eyes react instinctively to laser beam and protect themselves.
Class 3A	—	Dangerous if eyes are exposed to laser beam through optical means. Visible beam should be 5mW or less. Invisible beam should not exceed 5 times the Class 1 power.
Class 3B	—	Dangerous if eyes are exposed to laser beam directly. Unfocused, pulsed laser radiation 0.5W or less can be observed by means of diffuse reflection.
Class 4	—	Too intense. Even diffuse reflection is possibly dangerous. It can burn the skin or cause a fire.

Mounting

- The emitter and the receiver must face each other with proper slit orientation so that the beam can be received.

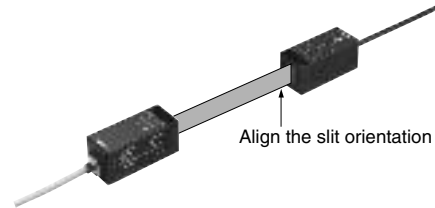

- The tightening torque should be 1.17N·m or less. When mounting the sensor with the attached sensor mounting bracket, the sensor must be fixed on both sides.

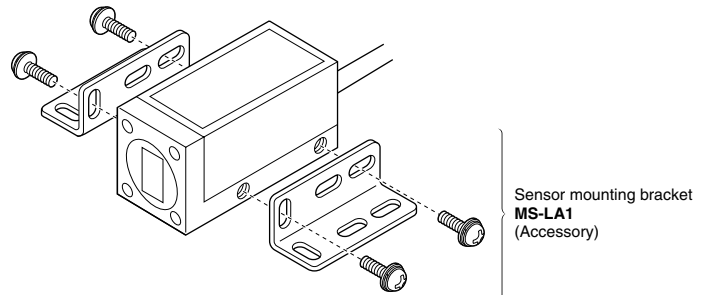

PRECAUTIONS FOR PROPER USE

Laser collimated beam sensor

Laser collimated beam alignment

- Place the emitter and the receiver so that they face each other along a straight line and align their positions until all yellow LEDs light off and the green LED lights up.

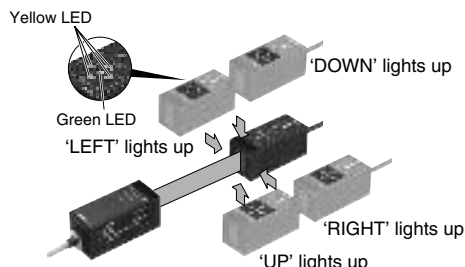

Span adjustment

- Turn the span adjuster until the analog voltage reaches +5V in the perfect light received condition (perfect beam alignment). As the span adjuster is turned clockwise, the analog voltage increases.

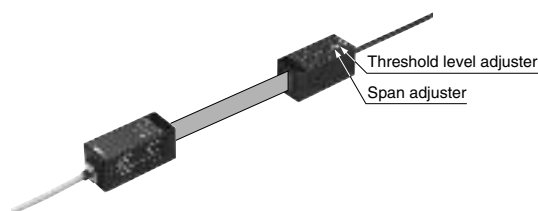

Threshold level adjustment

- The threshold level adjuster sets the threshold level of the comparative output. As the threshold adjuster is turned clockwise, the threshold level increases.

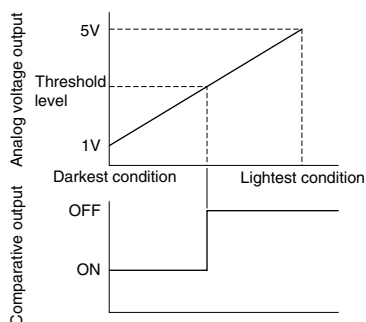

Wiring

- Make sure to carry out the wiring in the power supply off condition.
- Verify that the supply voltage variation is within the rating.
- If power is supplied from a commercial switching regulator, ensure that the frame ground (F.G.) terminal of the power supply is connected to an actual ground.
- In this product, capacitor earth is used to enhance the noise characteristics. In case there is a high frequency noise generating equipment, such as, an ultrasonic welding machine, etc., near the sensor head and if the mounting base is electrically conducting (metallic, etc.), then insulate the sensor head from the mounting base.

Do not use a power supply having a single-winding transformer (auto-transformer) as this can be dangerous.

- In case noise generating equipment (switching regulator, inverter motor, etc.) is used in the vicinity of this product, connect the frame ground (F.G.) terminal of the equipment to an actual ground.
- Do not run the wires together with high-voltage lines or power lines or put them in the same raceway. This can cause malfunction due to induction.

Others

- The sensor's output is proportional to the amount of laser beam received. Since there is some variation in the light intensity at the center and the periphery of the sensing area, take care that 'output = dimension' may not hold.
- For stable operation, use the sensor 10 min., or more, after switching on the power supply.
- Avoid dust, dirt, and steam.
- Take care that the sensor does not come in direct contact with water, oil, grease, or organic solvents, such as, thinner, etc.

PRECAUTIONS FOR PROPER USE

Laser sensor controller

Threshold level setting

• Operation panel description

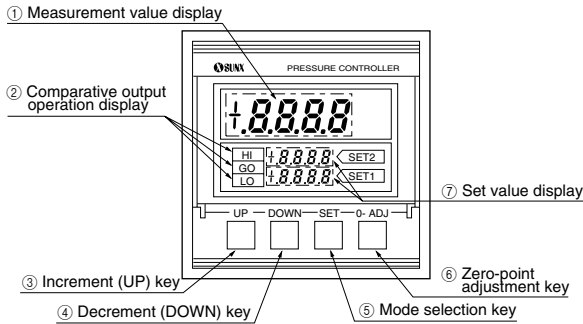

• Output mode

Two output modes are possible depending on the relative magnitudes of **SET 1** and **SET 2**.

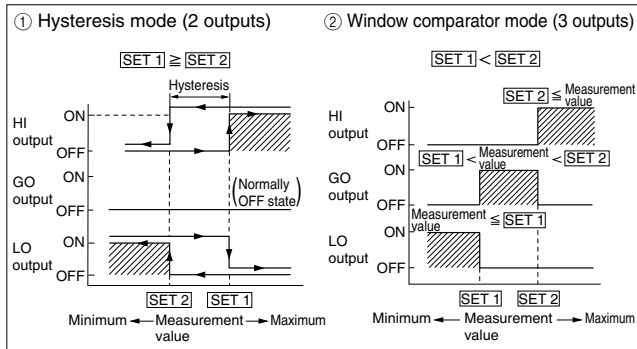

Note: In the window comparator mode, **SET 1** and **SET 2** should be separated by 2 digits or more.

• Setting method

SET 1, **SET 2** setting modes and **Sensing mode** can be cyclically selected by pressing the **SET** key.

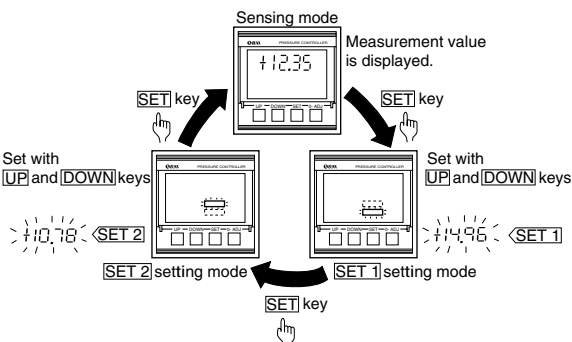

• Setting procedure

<Light width indication (indicated with '+')>

Step	Setting item	Display mode	Setting procedure
1	Zero-point adjustment	Sensing mode	Press the [0-ADJ] key under the Darkest condition (entire beam interrupted).
2	Full-scale adjustment	Sensing mode	Enter the sensor into the Lightest condition (entire beam is received). Turn the span adjuster until the displayed value becomes "+ 15.00".
3	SET 1 level setting	SET 1 setting mode	Use [UP] and [DOWN] keys to set the level of SET 1 . To increase the value, press the [UP] key. To decrease the value, press the [DOWN] key. + 19.99 + 19.98 ↑ [UP] + 0.00 - 19.98 ↓ [DOWN] - 19.99
4	SET 2 level setting	SET 2 setting mode	Set the level of SET 2 with [UP] and [DOWN] keys.
5	—	Sensing mode	Press the [SET] key to complete the setting procedure.

<Interrupted beam width indication (indicated with '-')>

After completing Step 2 'Full-scale adjustment' given above, press the **[0-ADJ]** key again.

The subsequent procedure is similar to that for 'Light width indication'.

Note: The output and operation display remain unchanged while **SET 1** or **SET 2** is adjusted.

★ If an error occurs, take the following corrective action.

Error code (Note 1)	Cause	Corrective action
Err 1	Short-circuit causing excess current flow.	Turn the power off and check the load.
Err 5	Set value exceeds the possible setting range (± 19.99) during the auto-reference input.	Check the set value.
- - - - (Note 2)	<ul style="list-style-type: none"> Input voltage exceeds 5.25V. The measurement value exceeds the display range ($- 19.99$ to $+ 19.99$). 	<ul style="list-style-type: none"> The input voltage should not exceed 5.25V. Keep the measurement value within the display range.

Notes: 1) The error code blinks in the measurement value display.

2) '- - - -' does not blink.

3) Please contact our office if 'Err 2' is displayed.

PRECAUTIONS FOR PROPER USE

Laser sensor controller

Auto-reference function

- The auto-reference function automatically shifts the set values to compensate for any change in the reference value at the time of auto-reference input.

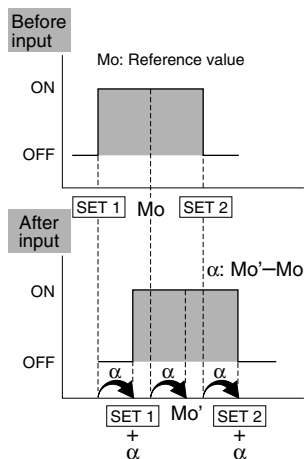

- In the sensing mode, the set values obtained after the auto-reference input are displayed. However, in the setting modes, the initial set values (in the application example, $\text{SET 1} = -0.5$ and $\text{SET 2} = +0.5$) are displayed.

Time chart

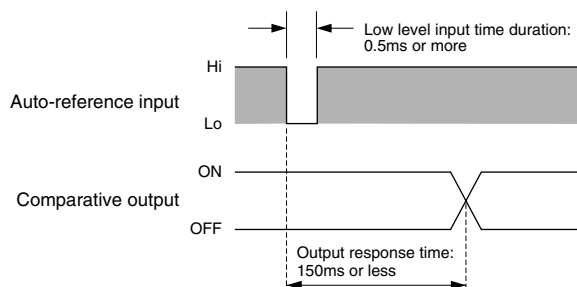

Note: Operation may be unstable (due to operation at the previous set values) for 150ms immediately after the auto-reference input is applied.

Application example

Monitoring wire thickness

- Let the tolerance be ± 0.5 for a standard workpiece ($\phi 2$).

$$\text{Set: } \text{SET 1} = -0.5$$

$$\text{SET 2} = +0.5$$

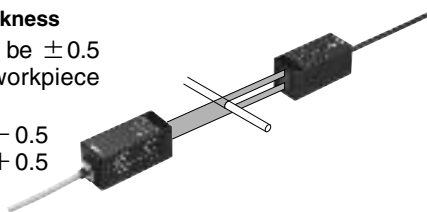

- Place the standard workpiece ($\phi 2$) within the sensing area and make the auto-reference input 'Low'. The set values get changed to

$$\text{SET 1} = 2 + (-0.5) = 1.5$$

$$\text{SET 2} = 2 + (+0.5) = 2.5$$

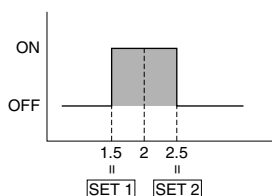

- In case the standard workpiece changes to $\phi 3$ and the tolerance is still ± 0.5 , place the standard workpiece ($\phi 3$) within the sensing area and make the auto-reference input 'Low'. The set values get changed to

$$\text{SET 1} = 3 + (-0.5) = 2.5$$

$$\text{SET 2} = 3 + (+0.5) = 3.5$$

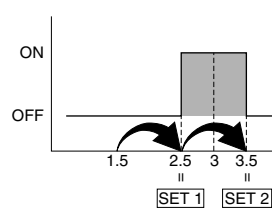

Wiring

- Make sure to carry out the wiring in the power supply off condition.
- Verify that the supply voltage variation is within the rating.
- If power is supplied from a commercial switching regulator, ensure that the frame ground (F.G.) terminal of the power supply is connected to an actual ground.
- In case noise generating equipment (switching regulator, inverter motor, etc.) is used in the vicinity of this product, connect the frame ground (F.G.) terminal of the equipment to an actual ground.
- Do not run the wires together with high-voltage lines or power lines or put them in the same raceway. This can cause malfunction due to induction.
- The tightening torque of screws on the terminal block should be 0.49N·m or less.

Others

- Do not use during the initial transient time (1sec.) after the power supply is switched on.
- Avoid applying an excess voltage (10V or more) on the sensor input terminals, as it may cause malfunction.
- Avoid dust, dirt, steam, and corrosive gas.
- Take care that the controller does not come in direct contact with water, oil, grease, or organic solvents, such as, thinner, etc.

DIMENSIONS (Unit: mm)

**LA-510
LA-511**

Laser collimated beam sensor

Emitter

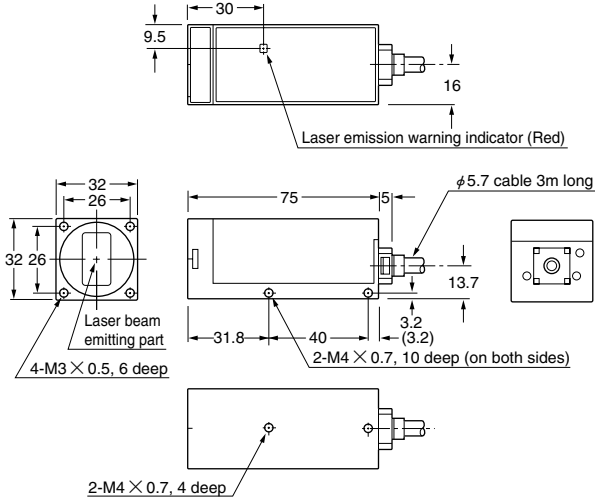

Receiver

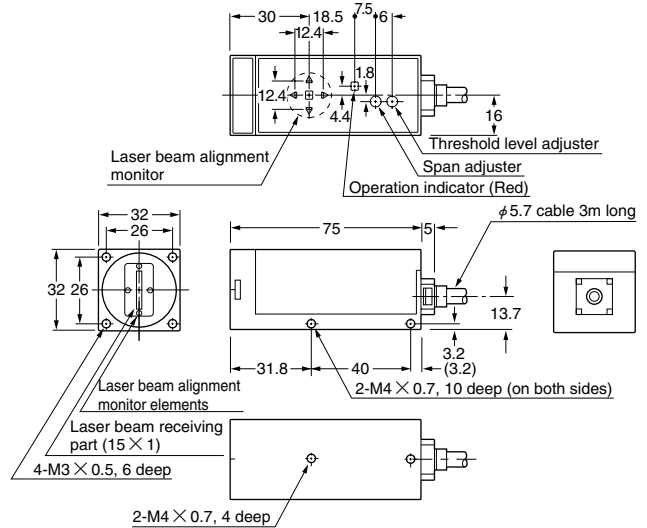

MS-LA1

Sensor mounting bracket (Accessory for LA-510 and LA-511)

Assembly dimensions

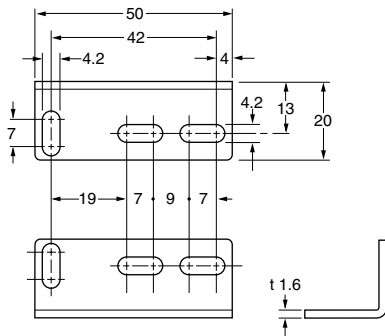

Material: Cold rolled carbon steel (SPCC)
(Uni-chrome plated)

Set of two L-shaped brackets and four
M4 (length 8mm) screws with washers

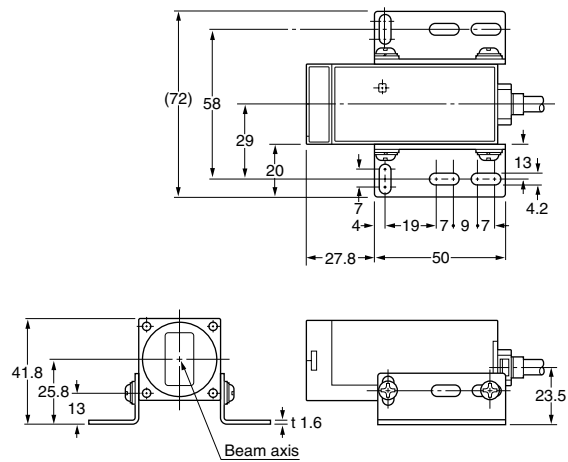

LA-SV1

Side view attachment (Optional)

Assembly dimensions

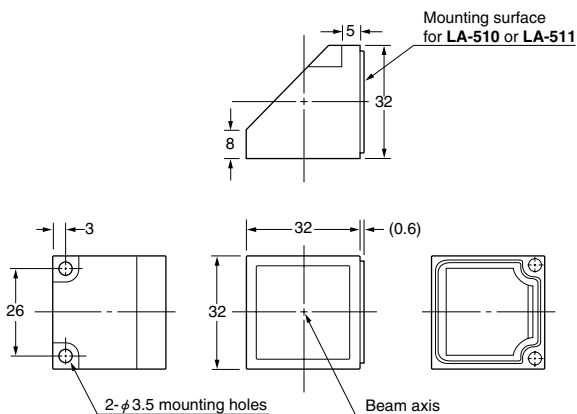

Material: Glass (Front protection cover, Aluminum evaporated mirror)
Polyetherimide (Enclosure)

Two M3 (length 10mm) screws with washers are attached.

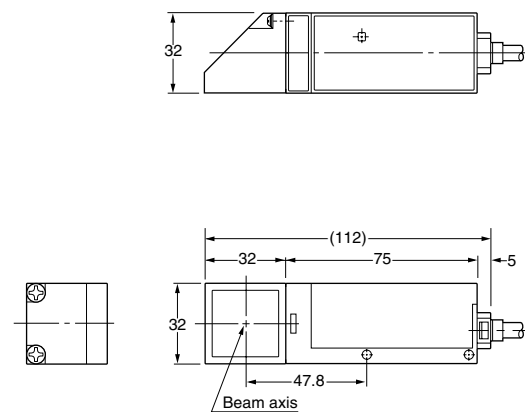

DIMENSIONS (Unit: mm)

LA-C1

Laser sensor controller

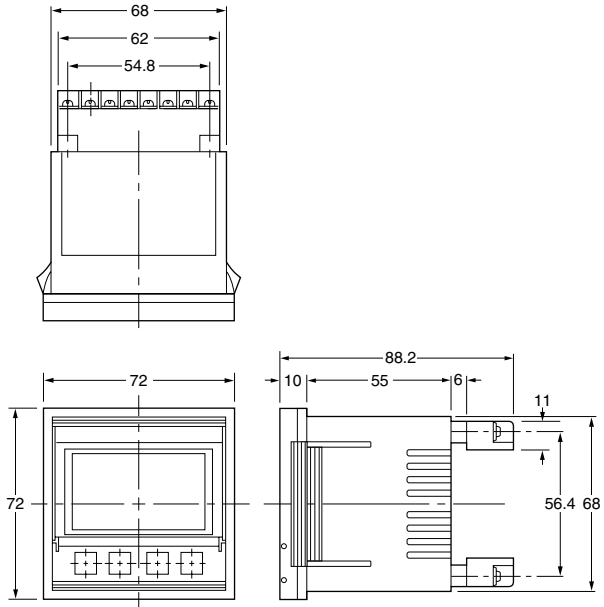

Panel cut-out dimensions

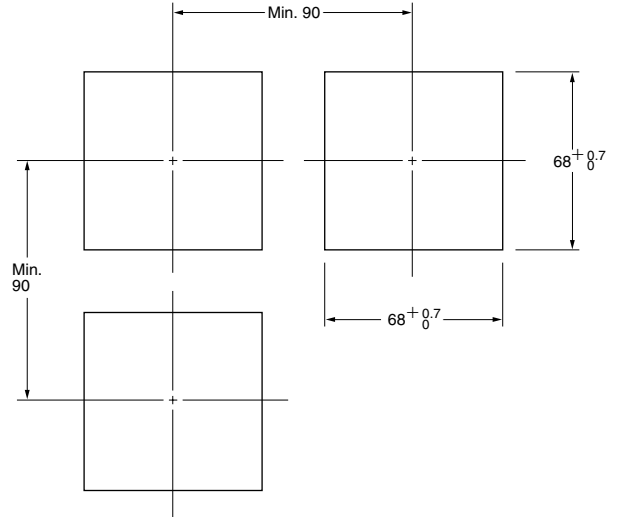

Note: The panel thickness should be 1 to 4mm.