Electromagnetic Flowmeter

Selection Manual

FUJIAN WIDE PLUS Precision Instruments Co., Ltd.

Contents

> Product applicability	1
> Working principle	1
> Instrument characteristics.....	1
> Ordering guide	2
> Brief performance introduction of WP-EMF series electromagnetic flowmeter	3
> Converter outline dimension.....	1
>Split-type sensor specifications	2
>Integrated-type sensor specifications	3
>Gripping-type sensor specifications	4
> WP-EMF-A/B flanged-type electromagnetic flow meter type spectrum table	4
>WP-EMF-C/D gripping-type electromagnetic flow meter type spectrum table	6
>Keyboard definition and terminal marking	2
>WP-EMF series electromagnetic flowmeter.....	2
>Flow meter aperture, flow rate with flow relation curve diagram.....	7
> Maximal flow selection reference scheme	9
> Lectotype notice.....	10
> Matters needing attention when cabling (split-type)	2
> Notice for sensor installation	2
> Appendix (electrode corrosion prevention performance reference table).....	18

WP Electromagnetic Flowmeter

> Product applicability

The electromagnetic flow meter is one kind of main flow instrument, widely apply to flow measurement for many industrial department such as petroleum, chemical industry, metallurgy, light and textile industry, papermaking, environment protection, food etc. and municipal management, water projects construction field etc..

> Working principle

The metering system of the electromagnetic flow meter primary is based on Faraday's laws of electromagnetic induction, on the channel border which is vertical each other with metering tube axis and line of magnetic field mount one pair detecting electrode, when the conductive liquid move along the metering tube axis the conductive liquid cutting the line of magnetic field induce the inductive E.M.F. This EMF detect out by two electrodes on the metering tube, numerical value size is:

$$E=KBVD$$

here: E - inductive EMF;

K - instrument constant;

B - magnetic induction

V - average flow velocity in metering tube section;

D - metering tube inner diameter;

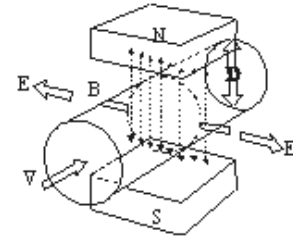

When measuring flow rate, the fluid flow through magnetic field verticaled to flow direction, the conductive liquid movement induce one EMF in direct proportion to average flow velocity, so that require measured flow liquid conductivity higher than lowest limit. Its induction voltage signal is detected by two electrodes, and pass through a cable transmit to converter, after through signal treatment and correlative operation, take the integrating flow and the instantaneous delivery indicate on the display screen of the converter.

> Instrument characteristics

- 1.1 In metering tube have not choked-flow and movable component, therefore it can not causes extra energy loss also can not causes stop up, so that its energy saving effect is remarkable, especial suit to measure liquid-solid two phase flow such as sewage, slurry, ore pulp, water-coal pulp, paper pulp and so on.
- 1.2 Of contact with measured medium only have liner and electrode, as long as reasonably select liner and electrode material it can attain good non-corrodibility and wear ability, so that can measure various acid and alkali chemical solution.
- 1.3 Installation demand is low. A straight upstream section only need 5D and downstream section is 2D (D is inner diameter of selected instrument).
- 1.4 Measurement accuracy non-subject to the influence for variation of the fluid density, viscosity, temperature, pressure and conductivity, also can measure positive / negative two directional flow rate, which has provided the very good means for precise measurement of flow rate.
- 1.5 Instrument watt consumption is small, lower than 5VA.
- 1.6 The Converter have good changeability, need not renew real flow calibrating can gain measurement

accuracy.

Because of the electromagnetic flow meter have a serial strong point, so that it gain the more the wider application in various industry, become a first choice instrument of liquid flow measurement.

> **Ordering guide**

Please user before order detail read this information; understand this product's model and coding rule, according to requirements determine model and specification. If need, please fill in the electromagnetic flow meter lectotype behavior table according to last page.

➤ Brief Performance Introduction of WP-EMF Series Electromagnetic Flowmeter



Model: WP-EMF-A

Installation modes: Flange integrated type

Language selection: Chinese and English

Aperture: DN10~DN800

Electrode material: 316, Hb, Hc, Ti, Ta

Inside lining material: PTEE, PFA, F46, chloroprene rubber (CR)

Medium: conducting liquid (include solid liquid two phase body)

Accuracy grade: 0.2%, 0.5%, 1.0% (DN10~DN200)

0.5%, 1.0% (DN250~DN2000)

Medium conductivity: $> 5 \mu S/cm$ (water $> 20 \mu s/cm$)

Excitation mode: LF square wave excitation, HF square wave excitation (apply to serosity measurement)

Flow velocity scope: 0.1~15m/s (flow unit selectable)

Connection flange: GB/T9119-2000

Medium temperature: -10~+60 ,

Rated pressure: 0.6Mpa~4.0Mpa (divided according to aperture, refer to type spectrum table)

Protection grade: IP67

Output signal: 4~20mA output, frequency/pulse, alarm

Hollow tube measurement: measuring hollow tube function without electrodes, continuous measurements, fix value alarm

Record function: record of power-fail time, automatic record of power break time of instrument system, make up flow left out (for option)

Infrared remote control: infrared hand-hold operational keyboard (for option)

Application: Acid, alkali, water supply and drainage, food, paper pulp, ore pulp etc.

Display: Flow rate, flow, percentage, integrating flow, fault alarm etc.

Supply power: 220V AC, 24V DC

Mark of explosion proof: Exd CT6 (for option)



Model: WP-EMF-C

Installation modes: Gripping integrated type

Language selection: Chinese and English

Aperture: DN40~DN200

Electrode material: 316, Hb, Hc, Ti, Ta

Inside lining material: PFA, F46

Medium: conducting liquid (include solid liquid two-phase body)

Accuracy grade: 0.2%, 0.5%, 1.0% (DN10~DN200)

Medium conductivity: $> 5 \mu\text{S/cm}$ (water $> 20 \mu\text{s/cm}$)

Excitation mode: LF square wave excitation, HF square wave excitation (apply to serosity measurement)

Flow velocity scope: 0.1~15m/s (flow unit selectable)

Connection flange: GB/T9119-2000

Medium temperature: -10~+60 ,

Rated pressure: 1.0Mpa~4.0Mpa (divided according to aperture, refer to type spectrum table)

Protection grade: IP67

Output signal: 4~20mA output, frequency/pulse, alarm

Hollow tube measurement: measuring hollow tube function without electrodes, continuous measurements, fix value alarm

Record function: record of power-fail time, automatic record of power break time of instrument system, make up flow left out (for option)

Infrared remote control: infrared hand-held operational keyboard (for option)

Application: Acid, alkali, water supply and drainage, food, paper pulp, ore pulp etc.

Display: Flow rate, flow, percentage, integrating flow, fault alarm etc.

Supply power: 220V AC, 24V DC

Mark of explosion proof: Exd CT6 (for option)



Model: WP-EMF-B

Installation modes: Flange split type

Language selection: Chinese and English

Aperture: DN10~DN2000

Electrode material: 316, Hb, Hc, Ti, Ta

Inside lining material: PTEE, PFA, F46, chloroprene rubber (CR)

Medium: conducting liquid (include solid liquid two phase body)

Accuracy grade: 0.2%, 0.5%, 1.0% (DN10~DN200)

0.5%, 1.0% (DN250~DN2000)

Medium conductivity: $> 5 \mu S/cm$ (water $> 20 \mu s/cm$)

Excitation mode: LF square wave excitation, HF square wave excitation (apply to serosity measurement)

Flow velocity scope: 0.1~15m/s (flow unit selectable)

Connection flange: GB/T9119-2000

Medium temperature: -10~+60 chloroprene rubber (CR), -10~+160 (PTFE)

Rated pressure: 0.6Mpa~4.0Mpa (divided according to aperture, refer to type spectrum table)

Protection grade: IP67, IP68

Output signal: 4~20mA output, frequency/pulse, alarm

Hollow tube measurement: measuring hollow tube function without electrodes, continuous measurements, fix value alarm

Record function: record of power-fail time, automatic record of power break time of instrument system, make up flow left out (for option)

Infrared remote control: infrared hand-hold operational keyboard (for option)

Application: Acid, alkali, water supply and drainage, food, paper pulp, ore pulp etc.

Display: Flow rate, flow, percentage, integrating flow, fault alarm etc.

Supply power: 220V AC, 24V DC

Mark of explosion proof: Exd CT6 (for option)



Model: WP-EMF-B

Installation modes: Flange split III type

Language selection: Chinese and English

Aperture: DN10~DN2000

Electrode material: 316, Hb, Hc, Ti, Ta

Inside lining material: PTEE, PFA, F46, chloroprene rubber (CR)

Medium: conducting liquid (include solid liquid two phase body)

Accuracy grade: 0.2%, 0.5%, 1.0% (DN10~DN200)

0.5%, 1.0% (DN250~DN2000)

Medium conductivity: $> 5 \mu S/cm$ (water $> 20 \mu s/cm$)

Excitation mode: LF square wave excitation, HF square wave excitation (apply to serosity measurement)

Flow velocity scope: 0.1~15m/s (flow unit selectable)

Connection flange: GB/T9119-2000

Medium temperature: -10~+60 chloroprene rubber (CR), -10~+160 (PTFE)

Rated pressure: 0.6Mpa~4.0Mpa (divided according to aperture, refer to type spectrum table)

Protection grade: IP67, IP68

Output signal: 4~20mA output, frequency/pulse, alarm

Hollow tube measurement: measuring hollow tube function without electrodes, continuous measurements, fix value alarm

Record function: record of power-fail time, automatic record of power break time of instrument system, make up flow left out (for option)

Application: Acid, alkali, water supply and drainage, food, paper pulp, ore pulp etc.

Display: Flow rate, flow, percentage, integrating flow, fault alarm etc.

Supply power: 220V AC, 24V DC



Model: WP-EMF-D

Installation modes: Gripping split type

Language selection: Chinese and English

Aperture: DN40~DN200

Electrode material: 316, Hb, Hc, Ti, Ta

Inside lining material: PFA, F46

Medium: conducting liquid (include solid liquid two-phase body)

Accuracy grade: 0.2%, 0.5%, 1.0% (DN10~DN200)

Medium conductivity: $> 5 \mu S/cm$ (water $> 20 \mu s/cm$)

Excitation mode: LF square wave excitation, HF square wave excitation (apply to serosity measurement)

Flow velocity scope: 0.1~15m/s (flow unit selectable)

Connection flange: GB/T9119-2000

Medium temperature: -10~+160 ,

Rated pressure: 1.0Mpa~4.0Mpa (divided according to aperture, refer to type spectrum table)

Protection grade: IP67

Output signal: 4~20mA output, frequency/pulse, alarm

Hollow tube measurement: measuring hollow tube function without electrodes, continuous measurements, fix value alarm

Record function: record of power-fail time, automatic record of power break time of instrument system, make up flow left out (for option)

Infrared remote control: infrared hand-hold operational keyboard (for option)

Application: Acid, alkali, water supply and drainage, food, paper pulp, ore pulp etc.

Display: Flow rate, flow, percentage, integrating flow, fault alarm etc.

Supply power: 220V AC, 24V DC

Mark of explosion proof: Exd CT6 (for option)



Model: WP-EMF-D

Installation modes: Gripping split III type

Language selection: Chinese and English

Aperture: DN40~DN200

Electrode material: 316, Hb, Hc, Ti, Ta

Inside lining material: PFA, F46

Medium: conducting liquid (include solid liquid two-phase body)

Accuracy grade: 0.2%, 0.5%, 1.0% (DN10~DN200)

Medium conductivity: $> 5 \mu S/cm$ (water $> 20 \mu s/cm$)

Excitation mode: LF square wave excitation, HF square wave excitation (apply to serosity measurement)

Flow velocity scope: 0.1~15m/s (flow unit selectable)

Connection flange: GB/T9119-2000

Medium temperature: $-10 \sim +160$,

Rated pressure: 1.0Mpa~4.0Mpa (divided according to aperture, refer to type spectrum table)

Protection grade: IP67

Output signal: 4~20mA output, frequency/pulse, alarm

Hollow tube measurement: measuring hollow tube function without electrodes, continuous measurements, fix value alarm

Record function: record of power-fail time, automatic record of power break time of instrument system, make up flow left out (for option)

Application: Acid, alkali, water supply and drainage, food, paper pulp, ore pulp etc.

Display: Flow rate, flow, percentage, integrating flow, fault alarm etc.

Supply power: 220V AC, 24V DC

➤ Converter outline dimension

Integrated-type

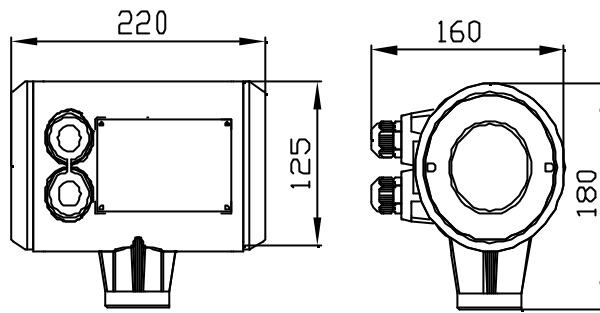

Split-type

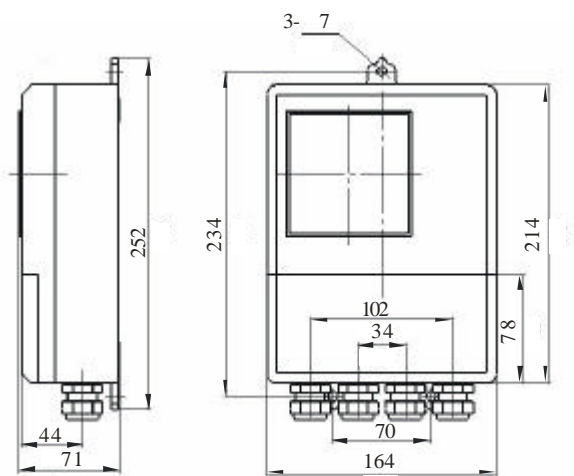
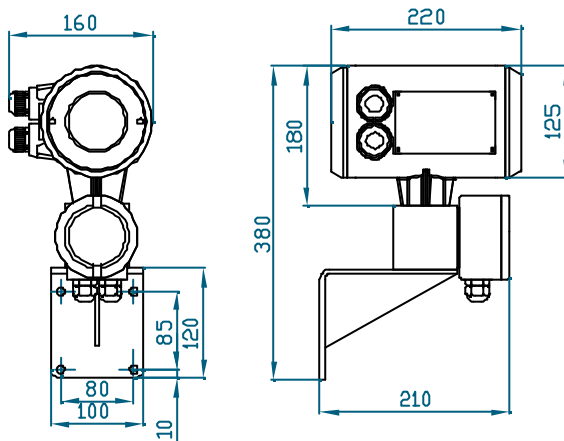

➤ Split-type sensor specifications

Aperture (mm)	Rated pressure (Mpa)	Instrument outline dimension (mm)			Flange connection dimension (mm)			Weight (kg)
		A	B	C	D	D ₀	n ×	
10	4.0	200	187	90	10	60	4 × 14	4
15	4.0	200	189	95	15	65	4 × 14	4
20	4.0	200	194	105	20	75	4 × 14	4
25	4.0	200	204	115	25	85	4 × 14	5
32	4.0	200	216	140	32	100	4 × 18	7
40	4.0	200	221	150	40	110	4 × 18	8
50	4.0	200	243	165	50	125	4 × 18	10
65	4.0	200	253	185	65	145	4 × 18	15
80	4.0	200	278	200	80	160	8 × 18	15
100	1.6	250	298	220	100	180	8 × 18	20
125	1.6	250	318	250	125	210	8 × 18	22
150	1.6	300	358	285	150	240	8 × 22	33
200	1.0	350	416	340	200	295	8 × 22	43
250	1.0	400	490	395	250	350	12 × 22	82
300	1.0	500	510	445	300	400	12 × 22	100
350	1.0	500	571	505	350	460	16 × 22	121
400	1.0	600	631	565	400	515	16 × 26	145
450	1.0	600	681	615	450	565	20 × 26	210
500	1.0	600	730	670	500	620	20 × 26	207
600	1.0	600	836	780	600	725	20 × 30	250
700	1.0	700	944	895	700	840	24 × 30	350
800	1.0	800	1055	1015	800	950	24 × 35	460
900	1.0	900	1170	1115	900	1050	28 × 35	550
1000	1.0	1000	1280	1230	1000	1160	28 × 35	680
1200	0.6	1200	1460	1405	1200	1340	32 × 35	770
1400	0.6	1400	1823	1524	1400	1560	36 × 36	1230
1600	0.6	1600	2033	1726	1600	1760	40 × 36	1550
1800	0.6	1800	2227	1926	1800	1970	44 × 39	2080
2000	0.6	2000	2428	2170	2000	2180	48 × 42	2600

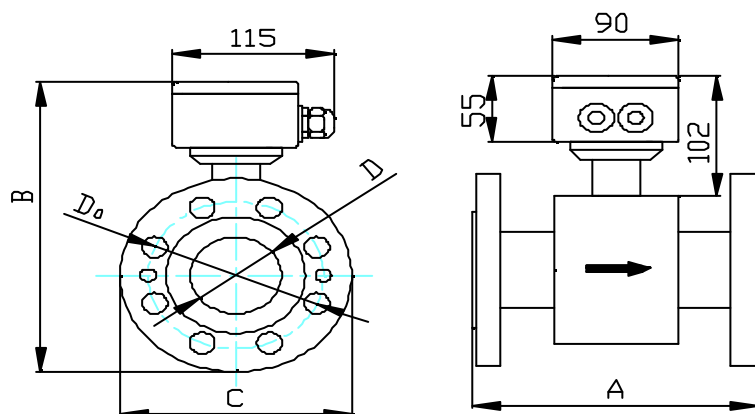

➤ Integrated-type sensor specifications

Aperture (mm)	Rated pressure (Mpa)	Instrument outline dimension (mm)			Flange connection dimension (mm)			Weight (kg)
		A	B	C	D	D ₀	n ×	
10	4.0	200	320	90	10	60	4 × 14	6
15	4.0	200	322	95	15	65	4 × 14	6
20	4.0	200	327	105	20	75	4 × 14	6
25	4.0	200	337	115	25	85	4 × 14	7
32	4.0	200	350	140	32	100	4 × 18	9
40	4.0	200	354	150	40	110	4 × 18	10
50	4.0	200	376	165	50	125	4 × 18	12
65	4.0	200	386	185	65	145	4 × 18	17
80	4.0	200	411	200	80	160	8 × 18	17
100	1.6	250	431	220	100	180	8 × 18	22
125	1.6	250	445	250	125	210	8 × 18	24
150	1.6	300	491	285	150	240	8 × 22	35
200	1.0	350	550	340	200	295	8 × 22	45
250	1.0	400	580	395	250	350	12 × 22	84
300	1.0	500	643	445	300	400	12 × 22	102
350	1.0	500	704	505	350	460	16 × 22	123
400	1.0	600	764	565	400	515	16 × 26	147
450	1.0	600	814	615	450	565	20 × 26	212
500	1.0	600	860	670	500	620	20 × 26	209
600	1.0	600	968	780	600	725	20 × 30	252
700	1.0	700	1077	895	700	840	24 × 30	352
800	1.0	800	1188	1015	800	950	24 × 35	462

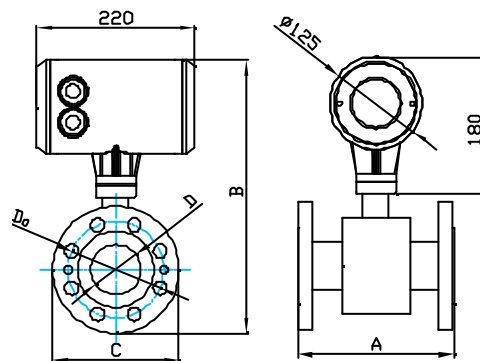

Note: Installation dimension for rubber liner the length need to increase 6~10mm, for polytetrafluoroethylene liner the length need to increase 6mm; for split structure; on the converter position in the diagram want to install wiring box, i.e. take wiring box replace the converter and take converter single separately mount on the wall or support frame.

➤ **Gripping-type sensor specifications**

➤ **Split-type**

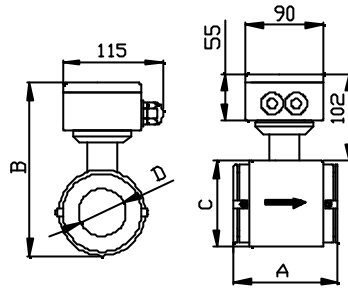

Aperture (mm)	Rated pressure (Mpa)	Outline dimension				Weight (kg)
		A	B	C	D	
40	4.0	80	187	85	40	3.0
50	4.0	100	202	100	50	3.6
65	4.0	120	222	120	65	4.5
80	4.0	120	234	132	80	5.2
100	1.6	150(204)	258	156	100	7.0
125	1.6	150	288	186	125	9.6
150	1.6	175	315	213	150	12.8
200	1.0	200	370	268	200	22

Integrated type:

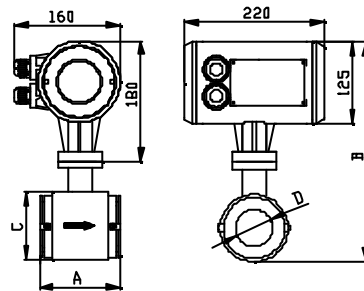

Aperture (mm)	Rated pressure (Mpa)	Outline dimension				Weight (kg)
		A	B	C	D	
40	4.0	80	315	85	40	3.0
50	4.0	100	330	100	50	3.6
65	4.0	120	350	120	65	4.5
80	4.0	120	362	132	80	5.2
100	1.6	150(204)	386	156	100	7.0
125	1.6	150	415	186	125	9.6
150	1.6	175	443	213	150	12.8
200	1.0	200	498	268	200	22

➤ WP-EMF-A/B flanged-type electromagnetic flow meter type spectrum table

Model											Explanation	
WP-EMF-												
Structure form	A											Integrated flanged-type electromagnetic flow meter
	B											Split flanged-type electromagnetic flow meter (with 10 meters cable when out of factory)
Aperture												Aperture from DN10~DN2000 (Numerical display)
Electrode			1									316 stainless steel
			2									Halloy B
			3									Halloy C
			4									Pt (not provide temporarily)
			5									Ti
			6									Ta
			9									Other
Lining material			A									Chloroprene rubber (CR)
			B									Polyurethane rubber (PU)
			C									Polytetrafluoroethylene (PTEE, F4)
			D									Solubility Polytetrafluoroethylene(PFA)
			E									F46
			G									Solubility Polytetrafluoroethylene (withstand negative pressure) (PFA)
			H									F46 (withstand negative pressure)
Working pressure			1									4.0MPa (aperture DN10~DN80)
			2									1.6MPa (aperture DN100~DN150)
			3									1.0MPa (aperture DN200~DN1000)
			4									0.6MPa (aperture DN1200~DN2000)
Earthing ring			A									None
			B									General earth ring
			C									Earth ring with neck
			B									IP67
			C									IP68 (split type)
Output mode			1									4~20mA
			2									0~3KHz
			3									Pulse X..XXX m ³ /cp
Communication mode			0									None
			1									RS485
			2									RS232C (match III type converter)
			3									HART (match III type converter)
Power supply			T									220V AC
			W									24V DC
Accuracy			4									0.2grade
			5									0.5 grade
			6									1.0 grade
			2									Integrated type
			3									Split I type
			6									Split III type

Flame-proof type			General type
		D	Flame-proof type (Exd II CT 6)
Max. flow		()	In the bracket give clear indication of max. flow, unit m ³ /h

For example: WP-EMF-A (100)1A2AA0T51D (80)

>WP-EMF-C/D gripping-type electromagnetic flow meter type spectrum table

Model													Explanation
WP-EMF-													
Structure form	C												Integrated flanged-type electromagnetic flow meter
	D												Split flanged-type electromagnetic flow meter (with 10 meters cable when out of factory)
Aperture													Aperture from DN10-DN200
Electrode			1										316 stainless steel
			2										Halloy B
			3										Halloy C
			4										Pt (not provide temporarily)
			5										Ti
			6										Ta
			9										Other
Lining material			D										Solubility Polytetrafluoroethylene(PFA)
			E										F46
			G										Solubility Polytetrafluoroethylene (withstand negative pressure) (PFA)
			H										F46 (withstand negative pressure)
Working pressure			1										4.0MPa (aperture DN10-DN80)
			2										1.6MPa (aperture DN100-DN150)
			3										1.0MPa (aperture DN200)
				B									General earth ring
				C									Earth ring with neck
Protection grade				A									IP65
				B									IP67
Output mode			1										4~20mA
			2										0~3KHz
			3										Pulse X...XXX m ³ /cp
Communication mode			0										None
			1										RS485
			2										RS232C
			3										HART
Power supply								T					220V AC
								W					24V DC
Accuracy			4										0.2grade
			5										0.5grade
			6										1.0grade
									2				Integrated type
									3				Split I type
									6				Split III type
Flame-proof													General type

		D	Flame-proof type (Exd II CT 6)
Max. flow		()	In the bracket give clear indication of max. flow, unit m ³ /h

For example: WP-EMF-C (100)1D2AA0T51D (80)

➤ Keyboard definition and terminal marking

>> Integrated and split I type keyboard definition and LCD display

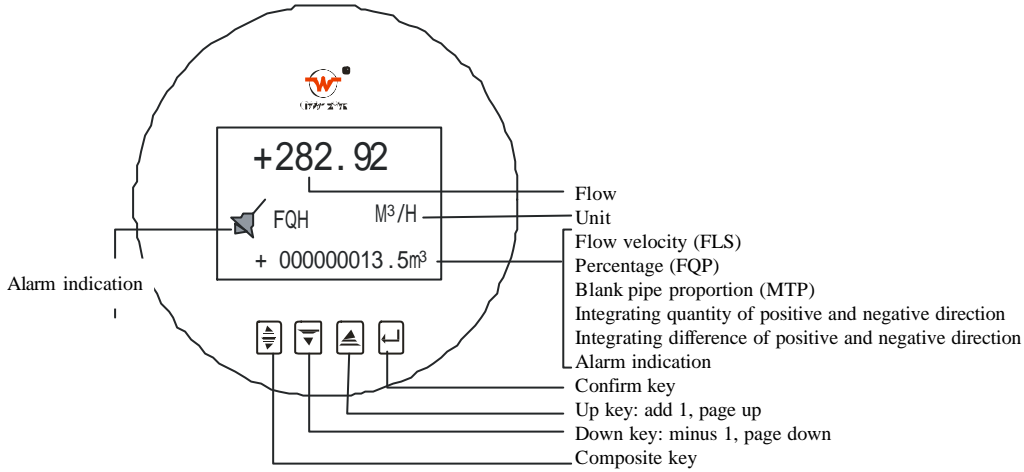

>> Split type keyboard definition and LCD display

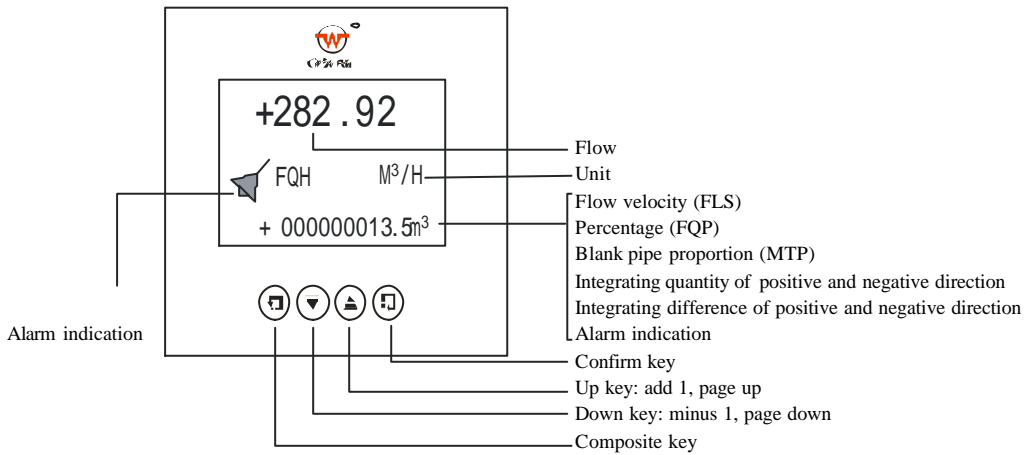

>> Integrated and split I type terminal wiring and marking

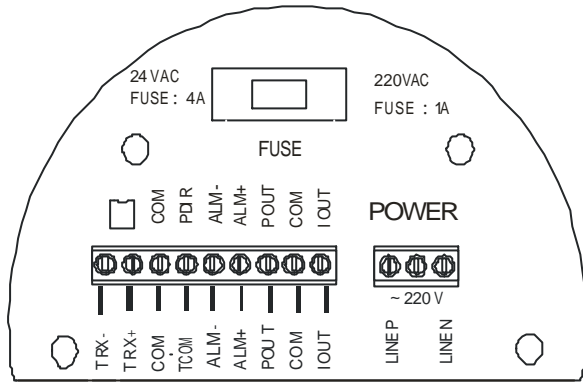

- IOUT Flow current output
- COM Current output place frequency (pulse) output place
- POUT Bi-direction flow frequency (pulse) output
- ALM- Lower limit alarm output
- ALM+ Upper limit alarm output
- COM Alarm output place
- PUSE Input power supply fuse
- TRX- Communicating input
- TRX+ Communicating input
- LINE P: 220V (24V) power input
- LINE N: 220V (24V) power input

>> **Split type terminal wiring and marking**

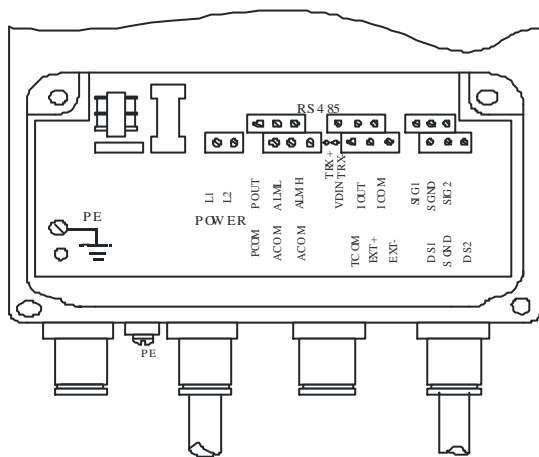

- SIG1 Signal 1
 - SGND Signal place
 - SIG2 Signal 2
 - DS1 Drive shield 1
 - DS2 Drive shield 2
 - EXT+ Excitation current +
 - EXT- Excitation -
 - VDIN Current two-wire system 24V connector
 - IOUT Analog current output
 - ICOM Analog current output place
 - POUT Flow frequency (pulse) output
 - PCOM Frequency (pulse) output place
 - ALMH Upper limit alarm output
 - ALML Lower limit alarm output
 - ACOM Alarm output place
 - TRX+ Communicating input
 - TRX- Communicating input
 - TCOM 232 communicating place
- Connect to split type sensor
- Analog current output
- Frequency or pulse output
- Double-loop alarm output
- Communication input

Remarks: if there is any changing for the above content, please subject to matching instruction book.

➤ **WP-EMF series Electromagnetic flowmeter**

>> **Features:**

WP-EMF series electromagnetic flowmeter is developed based on using experience in domestic and oversea fields. It is not only durable and easy to operate, but also has stable stability with HF and LF excitation which can adapt to bad environment in fields.

>> **Technical parameter:**

1 Analog current output:

Load resistance: when 0~10mA, 0~1.5 k ; when 4~20mA, 0~750

Basic error: 0.1% ± 10 μ A

2 Frequency output:

Frequency output range: 1~5000Hz

Output electric isolation: photoelectricity isolation. Isolating voltage: >1000V DC

Frequency output drive: field-effect tube output, max enduring voltage 36V DC, max load current 250mA

3 Pulse output:

Pulse output equivalent weight: 0.001~1.000m³/cp, 0.001~1.000Ltr/cp

Pulse output width: 50ms, automatically change into square wave when HF

Output electric isolation: photoelectricity isolation. Isolating voltage: >1000V DC

Pulse output drive: field-effect tube output, max enduring voltage 36V DC, max load current 250mA

4 Alarm output:

Alarm output connection point: ALMH - - - high limit alarm; ALML - - - low limit alarm

Output electric isolation: photoelectricity isolation. Isolating voltage: >1000V DC

Alarm output drive: Darlington transistor output, max enduring voltage 36V DC, max load current 250mA

5 Communication interface and protocol:

MODBUS interface: RTU format, physical interface RS-485, photoelectricity isolation 1000V

HART interface: support standard HART protocol, with HART handset, online display measuring value, and modify instrument parameter

6 Electric isolation

The insulation voltage between analog input and analog output is not less than 500V;

The insulation voltage between analog input and alarm power supply is not less than 500V;

The insulation voltage between analog input and AC power supply is not less than 500V;

The insulation voltage between analog output and AC power supply is not less than 500V;

The insulation voltage between analog output and earth is not less than 500V;

The insulation voltage between pulse output and AC power supply is not less than 500V;

The insulation voltage between pulse output and earth is not less than 500V;

The insulation voltage between alarm output and AC power supply is not less than 500V;

The insulation voltage between alarm output and earth is not less than 500V.

➤ **Flow meter aperture, flow rate with flow relation curve diagram**

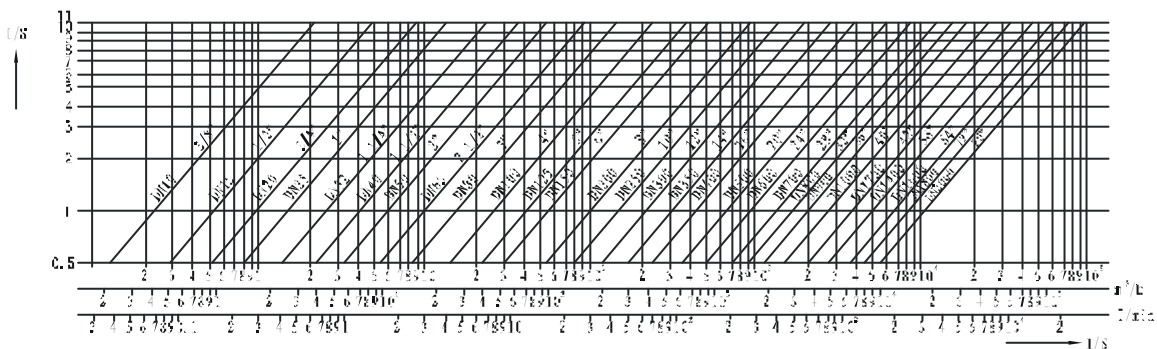

➤ **Maximal flow selection reference scheme**

Aperture (mm)	Max. flow selection (m ³ /h)
10	0.16、 0.2、 0.25、 0.3、 0.4、 0.5、 0.6、 0.8、 1.0、 1.2、 1.6、 2.0、 2.5
15	0.4、 0.5、 0.6、 0.8、 1.0、 1.2、 1.6、 2.0、 2.5、 3.0、 4.0、 5.0、 6.0
20	0.6、 0.8、 1.0、 1.2、 1.6、 2.0、 2.5、 3.0、 4.0、 5.0、 6.0、 8.0、 10.0、 12.0
25	1.0、 1.2、 1.6、 2.0、 2.5、 3.0、 4.0、 5.0、 6.0、 8.0、 10.0、 12、 16
32	1.6、 2.0、 2.5、 3.0、 4.0、 5.0、 6.0、 8.0、 10.0、 12、 16、 20、 25
40	2.5、 3.0、 4.0、 5.0、 6.0、 8.0、 10.0、 12、 16、 20、 25、 30、 40
50	4.0、 5.0、 6.0、 8.0、 10.0、 12、 16、 20、 25、 30、 40、 50、 60
65	6.0、 8.0、 10.0、 12、 16、 20、 25、 30、 40、 50、 60、 80、 100、 120
80	10、 12、 16、 20、 25、 30、 40、 50、 60、 80、 100、 120、 160
100	16、 20、 25、 30、 40、 50、 60、 80、 100、 120、 160、 200、 250

125	25、30、40、50、60、80、100、120、160、200、250、300、400
150	40、50、60、80、100、120、160、200、250、300、400、500、600
200	60、80、100、120、160、200、250、300、400、500、600、800、1000
250	100、120、160、200、250、300、400、500、600、800、1000、1200、1600
300	160、200、250、300、400、500、600、800、1000、1200、1600、2000、2500
350	200、250、300、400、500、600、800、1000、1200、1600、2000、2500、3000
400	250、300、400、500、600、800、1000、1200、1600、2000、2500、3000、4000
450	300、400、500、600、800、1000、1200、1600、2000、2500、3000、4000、5000
500	400、500、600、800、1000、1200、1600、2000、2500、3000、4000、5000、6000
600	600、800、1000、1200、1600、2000、2500、3000、4000、5000、6000、8000、10000
700	800、1000、1200、1600、2000、2500、3000、4000、5000、6000、8000、10000、12000
800	1000、1200、1600、2000、2500、3000、4000、5000、6000、8000、10000、12000、16000
900	1200、1600、2000、2500、3000、4000、5000、6000、8000、10000、12000、16000、20000
1000	1600、2000、2500、3000、4000、5000、6000、8000、10000、12000、16000、20000、25000
1200	2500、3000、4000、5000、6000、8000、10000、12000、16000、20000、25000、30000
1400	3000、4000、5000、6000、8000、10000、12000、16000、20000、25000、30000、40000、50000
1600	4000、5000、6000、8000、10000、12000、16000、20000、25000、30000、40000、50000、60000
1800	5000、6000、8000、10000、12000、16000、20000、25000、30000、40000、50000、60000
2000	6000、8000、10000、12000、16000、20000、25000、30000、40000、50000、60000、80000、100000

➤ Lectotype notice

On the premise of proper selection of electromagnetic flow meter that ensures to use electromagnetic flow meter well. Selection for electromagnetic flow meter must according to users' process flow, physical property and chemical property of measured fluid medium, installation and use environment and so on; in order to make parameters (such as electromagnetic flow meters' structure, path, flow scope, lining and electrode material, installation environment, output signal and so on.) satisfy measure requirement. In order to select flow meter correctly that can refer to some aspects as follows:

Selection for flowmeter path and range

As flow meter, which need to fix path and measure scope, namely fix flow velocity scope of sensor measure-tube. Selection for flow meter range span has much to do with improvement of reliability and precision. In terms of principle of over estimate max. flow value to choose full range; normal flow is not more than 50% of full range so that can gain higher measure precision

Sensor usually choose path that similar to or a little bit smaller than craft's. In the case of flow selected, selection of path depends on different measure objects and flow velocity of sensor measure-tube. Under measure principle, the flow velocity of electromagnetic flow meter can choose very high, sometimes even reach 10m/s, but under normal condition, the optimum flow velocity is 2~4m/s when considering the relation between flow velocity and pressure head. Under special condition, it depends on different use conditions. For example, if fluid with tube wall abrasion, usual flow velocity is 3m/s; if fluid with adhering tube wall, flow velocity is 2m/s. When measuring paper pulp, flow velocity above 4m/s; so that can automatically clean fibre that attaches electrode.

After making sure flow velocity, path of sensor can depend on the following formulas.

$$V = 3.5 \frac{Q}{d}$$

d path of sensor (mm), Q volume flow (m³/s)

When medium flow velocity in the tube within 0.3m/s~12m/s; caliber of sensor is the same as caliber of connective craft channel. This selection makes installation easily and does not use tubes with different diameter. At beginning, flow velocity is very low; latter on, flow velocity becomes higher. As long as change full range of the instrument can adapt, and do not replace the instrument. The relations between flow, flow velocity and caliber can refer to curve graph. (see page one)

The caliber of sensor may differ to the caliber of connective craft tube when encountering the following situations.

A. The pipe flow velocity is lower, the flow is more stable. To satisfy the requirement of flow velocity scope by the means of improving flow velocity of instrument partly. When caliber of sensor is smaller than the craft tube's, the back and forth of sensor need to joint tubes with different diameter

B. In terms of price, as electromagnetic flow meter with big caliber, the caliber is bigger, the price is higher. For the flow velocity is low and parameter is stable, we can choose sensor with smaller caliber. It not only make instrument in a good working state, but also reduce instruments' investment cost.

Selection of pressure

If measuring flow of negative pressure medium, we do not choose PTEF for lining; if there is special requirement asks for PTEF lining, it must in the negative pressure situation so that take up appropriate measurements while making PTEF lining.

Notes for tubes with different caliber installation

A. selection for cone angles of tubes with different diameter

In order not to influent distribution of flow velocity and precision of electromagnetic flow meter after installation for tubes with different diameter, make tubes with different diameter as a part of direct tube; requiring enter cone angle of tube with different diameter "a" not greater than 15°, the smaller, the better.

B. Installation for tubes with different diameter causes pressure loss

Total pressure loss has three parts:

pressure loss for deflating tube $P_1 = \frac{f}{2} \rho_1 V_1^2$

pressure loss for inflating tube $P_3 = \frac{f}{2} \rho_3 V_3^2$

pressure loss for measure tube of sensor $P_2 = \frac{f}{2} \rho_2 V_2^2$

total pressure loss is

$$\Delta P = 0.01(\rho_1 \Delta P_1 + \rho_2 \Delta P_2 + \rho_3 \Delta P_3)(\text{unit:Pa})$$

In formula, ρ is medium density, unit is kg/m³

ρ₁ ρ₃ respectively means parameters of deflating tube and inflating tube that relate to reynolds number;

ρ₂ = 0.02 is parameter of sensor measure tube

V₁, V₂ respectively means flow velocity of craft pipe and sensor measure tube, unit is m/s

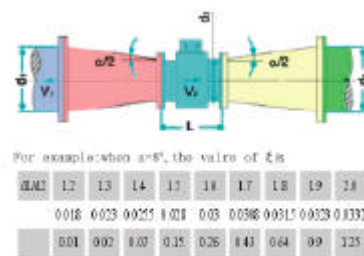

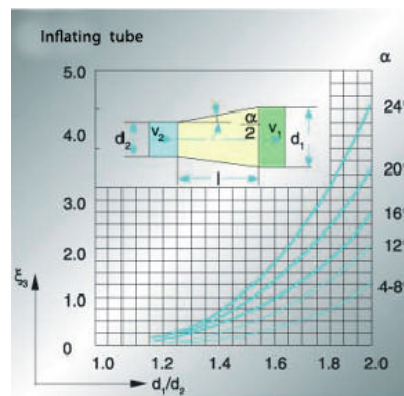
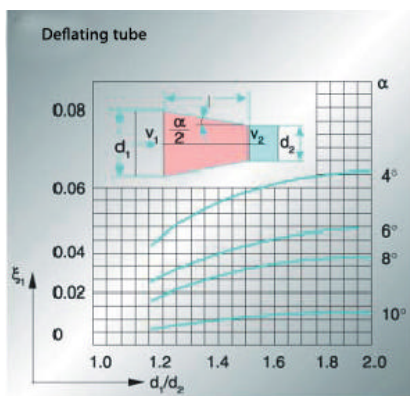

Selection of electrode material

User is responsible for selection which must according to corrosiveness of measured medium. For general medium, user can refer to 在 the anti-corrosion manual. When choosing electrode material, user must do experiments about medium with complex ingredient.

Electrode material	Corrosion-proof performance
1Cr18Ni9Ti 0Cr18Ni12Mo2Ti	It has anti-corrosion effect on medium, such as nitric acid, phosphoric acid and other cold inorganic acid, solution with alkali and salt, organic acids, seawater and so on. When it encounter medium, such as vitriol, hydrochloric acid, hydrofluoric acid, boiling formic acid, boiling oxalic acid, chromic acid industry, as well as sodium and chlorine, bromine and iodine, it has poor chemical stability. Therefore, it adapts to non-corrosion or poor-corrosion medium, such as water, sewage, ore magma, slop, fiber slurry, syrup and other fluid. It has anti-corrosion effect on medium, such as nitric acid, vitriol less than 5% at room temperature, boiling phosphoric acid, formic acid, aqueous alkali, sulfurous acid under a certain pressure, seawater, acetic acid and so on. It can be widely used in petrochemical, urea, vinylon and other industries.
HB	It can resist corrosion from all concentration of hydrochloric acid under boiling point; as well as vitriol, phosphoric acid, organic acids and other non-oxidizing acids, alkali, non-oxidizing salt liquid.
HC	It can resist corrosion from oxidizing acid, such as nitric acid, chromic acid or vitriol, and other mixed acid. It also can resist corrosion from oxidizing salt, such as Fe ⁺⁺ , Cu ⁺⁺ or other oxidants, hypo-argon hydrochloric acid solution that above normal temperature, and grease.
Ti	It can resist corrosion from grease, various chloride salt and sub-chloride, oxidizing acid (including fuming vitriol, nitric acid), organic acid, alkali and so on. It cannot resist corrosion from pure reducing acid (such as vitriol, hydrochloric acid); but if acid with hydrogenated agent, the corrosion reduce.
Ta	It has well anti-corrosiveness, similar to glass. It can resist corrosion from almost any chemical medium expected hydrofluoric acid, oleum and alkali.

Selection of lining material

Selection must according to corrosiveness, wearability and temperature of the measured medium. Neoprene can resist general weak acid, alkaline corrosion and temperature of 80 ; has wear resistance. PTFE almost can resist strong acid, alkaline corrosion, heat-phosphate excepted. Medium temperature can reach 180 , but not has wear resistance. Urethane rubber has better wear resistance, but not resists acid and alkaline corrosion; has poor temperature resistance. Medium temperature below 65 .

Characteristics of lining material and applicability

Lining material	Main characteristics	Applicability
PTFE, F4	1. It is one of the most stable chemical properties plastic	1. Long-term usage temperature

	<p>materials. It can resist boiling hydrochloric acid, vitriol, nitric acid, aqua regia, strong caustic and various organic solvents.</p> <p>2. Poor wear resistance and cementation characteristic</p>	<p>of flow meter: -40 ~+180</p> <p>2. Strong corrosive medium, such as acid, alkaline and so on.</p> <p>3. Sanitary medium</p>
F46	1. Anti-corrosiveness the same as PTFE	The same as PTFE
PFA	<p>1. Its chemical stability, electric insulativity, lubricating property, in-viscosity and incombustibility is similar PTFE; but PFA material intension and resistance to aging excel PTFE</p> <p>2. It has well cementation characteristic with metal, wear resistance excel PTFE, F46.</p> <p>3. Low smoke, flame retardant, high temperature, high-temperature mechanical strength is two times higher than PTFE.</p>	<p>1. Long-term usage temperature of flow meter: -40 ~+160</p> <p>2. Strong corrosive medium, such as acid, alkaline and so on.</p> <p>3. Sanitary medium</p>
CR	<p>1. It has better elasticity, strong breaking tenacity and well wear resistance</p> <p>2. Its resists corrosion of general acid with low concentration, alkaline and salt medium.</p>	<p>1. <80</p> <p>2. Measure general water, sewage, slop, ore pulp</p>
PU	<p>1. It has better wear resistance (ten times as natural rubber)</p> <p>2. Poor anti-acid and anti-alkaline</p>	<p>1. <60</p> <p>2. Neutral strong wearing ore pulp, coal slurry, slop</p>

Selection for protection rank

According to national standards GB4208—84 and international electrician committee IEC standard (IEC529--76), shell protection rank is:

IP65 is spraying-proof type, namely admit tap sprays water over instrument from any direction. Spraying pressure is 30KPa (0.3 bar). Hydraulic discharge is 12.5 litre/centimeter. Distance from spot to instrument is 3 meter. IP67 is soaking-proof type, namely instrument can totally be soaked in the water for a short time. When testing, the highest point at least 150 cm underwater, lasting at least 30 minutes. IP 68 is diving type, it can operate underwater for long term, and the maximum depth of soaking is arranged by manufacturer and user.

Selection principle for protection rank must according to the above requirement and actual condition of instrument. If the instrument is often soaked underground, user should choose IP68; if the instrument is fixed over the ground, user should choose IP65.

Selection for ground ring

If the channel that connect instrument is insulativity (relative to measured medium), it need ground ring, and can use general or PVC type. Its material is fitting corrosiveness of measured medium.

If measured medium is abrasive, user should use ground ring with neck so that to protect entrance or exit point of lining and prolong service life.

Selection of cable length

1. The relationship between L_{max} and medium conductivity, excitation cable copper core interfacial area A , type of signal cable is expressed by the following curve.

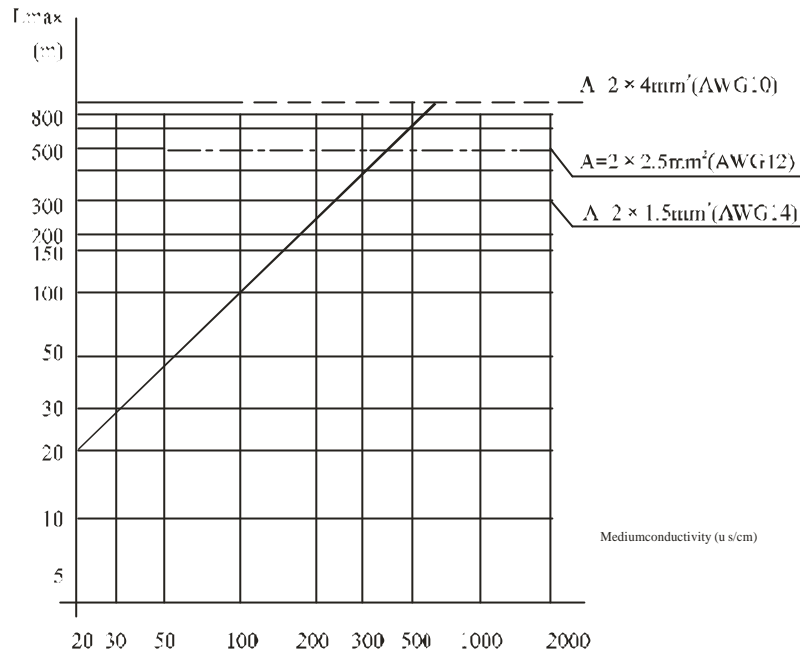

Notebook : the curve means double shielding signal cable

Types of excitation cable generally select YZ medium rubber cable. ($2 \times 1.0 \text{ mm}^2$, outer diameter is 10)

Shorter one selection of permissible maximum length of signal cable and excitation cable, namely is permissible maximum distance between sensor and converter.

For example: common tap water or raw water, its conductivity is between 100~500 $\mu\text{S/cm}$, select excitation cable copper core interfacial area $A = 2 \times 2.5 \text{ mm}^2$. if conductivity is 200 $\mu\text{S/cm}$, signal cable $L_{\text{max}} = 200\text{m}$, excitation cable $L_{\text{max}} = 500\text{m}$.

2. Length of output signal transmission cable

A. output current transmission cable

The maximum length of cable can be fixed by the following formula

$$R_0 + R < 1.2\text{K} \quad (10 \text{ mA output})$$

$$R_0 + R < 600 \quad (10 \text{ mA output})$$

R is input resistance total number of posterior position instrument.

R_0 is resistance value of transmission cable.

The maximum length can be obtained by R_0 value and conductor interfacial area, real distance is half of maximum length.

B. Output frequency o transmission cable

For distributed capacitance is 200 pf/m cable, maximum length is 200m.

3. The features of connecting wire and cable and connection requirements

1 Flow signal wire

When split-type converter works with sensor and the conductivity of measured liquid is more than 50 $\mu\text{S/cm}$, the flow signal transmitting cable could adopt model PVVP $2 \times 0.2 \text{ mm}^2$ PVC sheath wire netting shielded signal cable. The length should not be more than 100m. Signal wire and sensor will leave the factory as a complete set.

This converter provides equipotential driving and shielded signal output voltage so as to decrease the influence caused by distributed capacitance for cable transmission on flow signal measurement. When the measured conductivity is small and for long-distance transmission, twin-core and doubling shielded signal

cable with equipotential shield could be adopted, such as STT3200 appropriate cable or BTS triple shielded signal cable.

2 Excitation electric streamline

Twin-core insulated rubber flexible cable could be used for excitation electric streamline, suggested model: RVVP 2*0.3 mm². The length of excitation electric streamline should be accordance with signal cable's length. When using STT3200 appropriate cable, the excitation cable and signal cable should be merged into one cable.

3 Output and power line

All the output and power line should be prepared by users according to their actual conditions. But please pay attention to meeting the requirement of load current.

Matters needing attention when cabling (split-type)

1. The input signal wire of converter should thread the steel pipe separately and the steel pipe should connect with earth.
2. Signal cable and excitation cable should not be installed parallel to other cables, such as motor cable, transformer cable or other driving cables. Their distance should be more than 1 m.
3. Signal cable and excitation cable should neither cut off nor open circuit in the midway nor extend its length by welding or other connecting methods.
4. Excitation terminal should neither be short circuit nor connect other load except converter's excitation winding.

Sensor ground

In order to make instrument work effectively, enhance measuring accuracy and without interference of external parasitic potential, sensor should have well individual grounding wire, ground resistance < 10 Ω. Tube that connects sensor, if the inner wall of tube is painted with insulating layer or is non-metal tubes, both sides of sensor should be equipped with ground ring.

1. Forms of ground ring

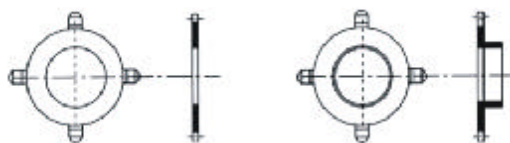

1. general or PVC ground ring

2. Ground ring with neck

A. general or PVC ground ring

material: selectable

thickness: 5mm~ 12mm

used for PTFE lining sensor, by fixing screws on the flange, protect PTFE turn up edging.

B. Ground ring with neck

material: selectable

thickness: 5mm

ground ring with neck is used for wear mediums, such as mud, ore pulp, coal water slurry and so on. It can protect end lining of measuring tube; prolong the service life of sensor. The ground ring should be

ordered with instrument, or else the instrument without this ground ring will influence its accuracy.

2. Ground modes

A. Installation of sensor on the metal tube: the inner wall of metal tube without insulating layer, ground as following picture.

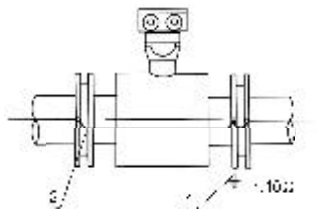

1. Ground device wire (install when external inference is stronger)
2. Instrument ground wire

B. installation of sensor on the plastic tube or tube with insulating coating or paint: two ends of sensor should install ground ring (or short tube with ground wire), make short circuit between measured flow medium in the tube and earth, and have zero potential. Or else, electromagnetic flow meter cannot work normally.

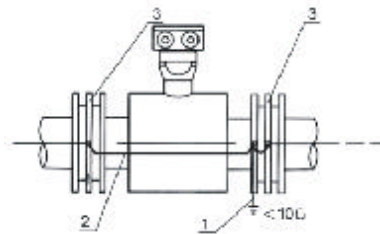

1. Ground device wire (install when external inference is stronger)
2. Instrument ground wire
3. Ground flange or ground ring

Installation of sensor on the cathode protection tube

Installation of sensor on the cathode protection tube: certain potential difference between cathode protection tube and earth, therefore, measured medium has very high common mode grounding potential. So, sensor must use ground ring.

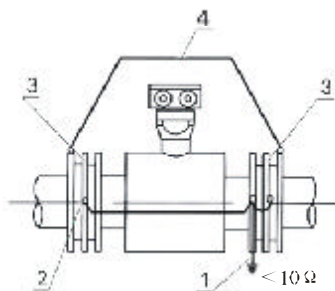

1. Ground device wire (install when external inference is stronger)
2. Instrument ground wire
3. Ground flange or ground ring, must insulate with connecting tube flange.
4. connecting wire, copper core interfacial area is $16(\text{mm})^2$, let cathode protect potential and isolate from sensor.

Note:

(1) Ground rings are installed on the second end surface of sensor, they must insulate from flange that connect tubes. Use ground wire 2 of instrument to connect with sensor and ground ring. The material of ground ring is anti-corrosive, the standard material that manufacturer provides is stainless steel 1Cr18Ni9Ti.

(2) Flange that connect tube in both sides of instrument should use copper wire which interfacial area is 16mm², let cathode protect potential and isolate from sensor.

Have cathode anti-corrosive protection tube, sensor and connecting tube are insulating. Take the following notes when fixing:

- Ground rings that insulate tube flange must simultaneously install at the both ends of flow meter. Connect between ground rings, flow meter and ground device wire.
- Use copper cable to connect tube flanges, but not connect sensor.
- Flange that connect bolt should be insulating. User must use bush and washer which are made up of insulating material.

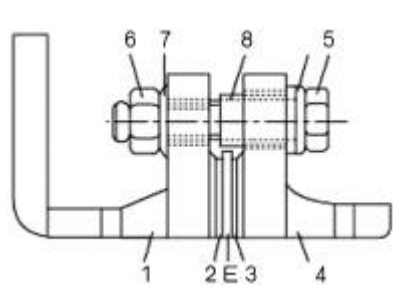

- | | | |
|----------------|------------------|--------------------|
| E. ground ring | 1. Sensor flange | 2. Lining |
| 3. Seal ring | 4. Pipe flange | 5. Bolt |
| 6. Nut | 7. Washer | 8. Insulating bush |

Installation suggestion

In order to avoid measuring error that caused by liquid bubble and damage for PTEE and rubber lining, please refer to the following figures:

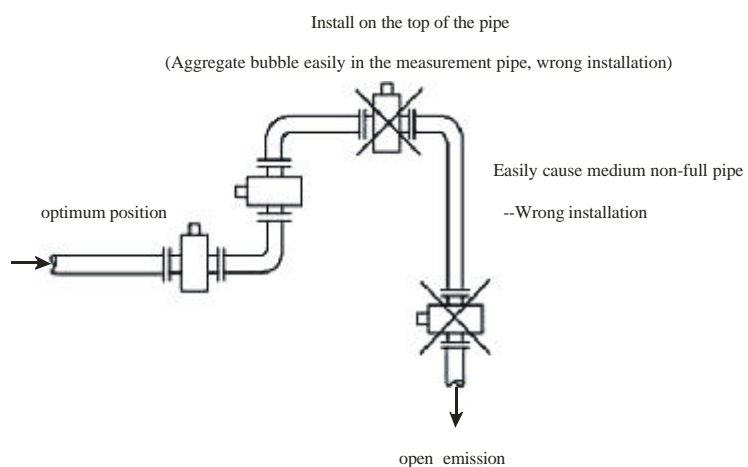

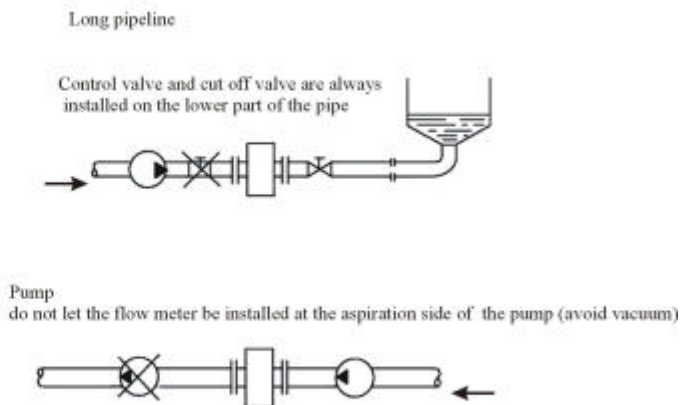
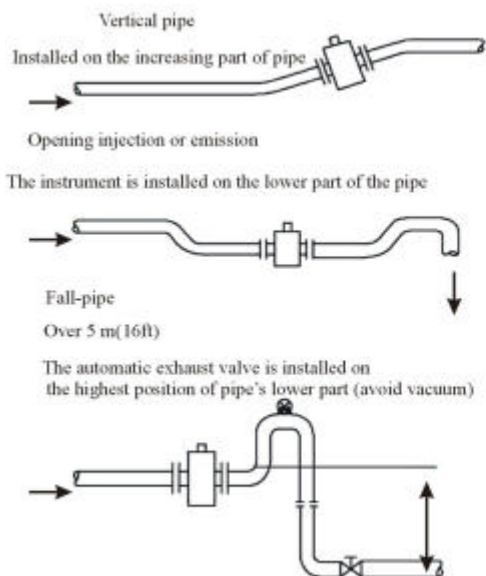

➤ **Appendix (electrode corrosion prevention performance reference table)**

Contact liquid material Liquid name		Electrode material			
		Mo2Ti	Halloy C	Ta	Ti
Perchloric acid	(50%)	N	N	A	B
Poenol	(10%)	B	B	A	
Phosphoric acid	(100%, 20)	N	B	A	
Phosphoric acid	(25%, 180)	N	B	A	N
Phosphoric acid	(50%, 180)	N	B	A	N
Phosphoric acid	(50%, 60)	N	B	A	N
Phosphoric acid	(80%, 180)	N	B	A	N
Phosphoric acid	(80%, 60)	N	B	A	N
Aluminium potassium sulfate	(100%)	B	N	A	A
Potassium carbonate	(100%)	B	B	A	B
Potassium chloride	(50%)	B	N	A	A
Dichromic kalium	(100%)	A	N	A	
Ferricyanic acid kalium	(100%)	N	N	A	
Ferrocyanide kalium	(100%)	N	N	A	
Potassium acid carbonate	(100%)	B	B	A	
Caustic potash	(25%, 180)	N	N	N	N
Caustic potash	(50%, 180)	N	N	N	N
Niter	(80%)	N	N	B	A
Potassium hypermanganate	(10%)	N	N	B	B
Potassium peroxydisulfate	(10%)	B	B	A	A
Potassium sulfate	(100%)	B	N	A	B

Seawater		N	N	A	A
Niter	(50%)	N	B	B	B
Sodium acetate	(100%)	N	N	A	A
Sodium bicarbonate	(100%)	N	N	A	
Sodium bromide	(100%)	N	N	A	A
Sodium carbonate	(100%)	B	B	B	A
Sodium chlorate	(40%)	N	N	A	B
Sodium chlorite	(30%)	N	N	A	A
Sodium chromate	(40%)	N	N	A	A
Sodium cyanide	(100%)	N	N	A	A
Sodium dichromate	(100%)	N		A	
Ferricyanic acid sodium	(100%)				
Sodium fluoride	(100%)	N		N	
Baking soda	(100%)	N	N	N	
Sodium acid sulfate	(30%)	B	B	A	A
Hydrosulfuric acid sodium	(100%)	N	N	A	A
Ferrocyanic acid sodium	(100%)	B	N	A	
Sodium sulfite	(100%)	N	B	A	
Caustic soda	(100%)	B	B	A	
Caustic soda	(30%, 180)	N	B	N	B
Caustic soda	(40%, 70)	B	A	N	B
Caustic soda	(40%, 90)	B	A	N	B
Caustic soda	(50%, 180)	N	B	N	B
Sodium hypochlorite	(15%)	N	B	A	A
Sodium hypochlorite	(25%)	N	B	B	B
Sodium metaphosphate	(100%)				
Chile nitre	(40%)	N	B	A	B
Sodium nitrite	(40%)	N	N	A	A
Butter of tin	(100%)	N	N	A	N
Vitriol	(100%, 60)	N	N	A	N
Vitriol	(30%, 180)	N	A	A	N
Zinc chloride	(50%)	N	N	A	A
Aldehyde	(100%)	B	A	B	A
Acetic acid	(50%)	B	A	A	A
Acetic acid	(75%)	N	A	A	
Alum	(100%)	N	N	A	N
Aluminium chloride	(100%)	N	N	B	
Aluminium chlorate	(100%)	N	N	A	N
Aluminium fluoride	(100%)	N	N	N	
Aluminium hydrate	(100%)	B	N	A	B

Aluminium nitrate	(100%)	N	N	N	B
Aluminium sulfate	(100%)	B	B	A	
Amino vitriol	(100%)	N	N	A	A
Ammonium carbonate	(50%)	N	N	A	B
Ammonia chloride	(30%)	N	B	A	B
Ammonium fluoride	(100%)	N	B	N	
Ammonium acid carbonate	(50%)	N	N	A	N
Hydrofluoric acid ammonia	(50%)	N	B	N	A
Ammonia	(100%)	B	B	N	B
Ammonium nitrate	(100%)	N	B	A	N
Ammonium peroxydisulfate	(100%)	N	N	A	
Ammonium tertiary phosphate	(100%)	N	N	A	B
Ammonia sulfate	(20%)	N	N	A	
Ammonium sulfide	(100%)			B	
Antimony pentachloride	(100%)	N	N	A	
Antimonous chloride	(100%)	N	N	A	B
Aqua regia	(100%)	N	N	A	
Arsenic acid	(100%)	N	N	A	
Arsenious acid	(100%)	N	N	A	
Barium acetate	(100%)	N	N	A	
Barium carbonate	(100%)	N	N	A	B
Barium chloride	(30%)	N	B	A	N
Barium hydroxide	(100%)	B	N	A	B
Barium sulfate	(50%)	N	N	A	
Barium sulfide	(100%)	N	N	A	
Phenyl-hydrogen-sulfate	(100%)	N	N	A	
Boric acid ammonium	(100%)	N	N	A	
Calcium chloride	(100%)	N	N	A	A
Calcium carbonate	(100%)	B	B	A	B
Chloric acid calcium	(30%)	N	N	B	B
Calcium chloride	(40%)	N	N	A	
Calcium bisulfate	(100%)	N	N	A	A
Calcium hydroxide	(50%)	N	B	A	A
Sodium silicate	(100%)	N	N	A	
Sodium sulfate	(100%)	N	N	A	B
Sodium sulfide	(100%)	N	N	A	A
Sodium sulfite	(30%)	B	N	A	
Sodium tetraborate	(100%)	B	B	A	A
Sodium hyposulfite	(100%)	N	A	N	A

Calcium hypochlorite	(100%)	N	N	A	
Lime nitrate	(10%)	N	N	A	
Calcium sulfate	(100%)	N	N	A	
Chloroacetic acid	(100%)	N	B	A	
Chromatosulfuric acid	(50%)	N	B	A	
Chromic acid	(100%)	N	N	A	A
Chromium fluoride	(100%)				
Chromic acid	(50%)	N	N	A	
Chromic sulfate	(100%)	N	B	A	
Cupric cyanide	100%	B	B	A	B
Copper fluoride	100%	N	N	N	N
Cupric nitrate	50%	N	N	A	B
Copper hydroxide	100%	N	N	N	
Cupric sulfate	40%	B	B		B
Copper sulfide	100%	B	B	A	B
Ferric chloride	50%	N	N	A	
Iron trichloride	50%	N			
Iron sulfide	100%		B		
Ferrous chloride	100%	N	N	A	
Ferric nitrate	100%	N	B	A	N
Ferric sulfate	100%	N	N	A	N
Boratofluoric acid	100%	N	N	N	
Silicofluoric acid	40%	N	N	N	
FSO ₃ H	100%	N			N
Formaldehyde	100%	N	B	A	
Formic acid	80%	N	N	A	A
Glacial acetic acid	100%	N	A	A	N
Glycerine (propanetriol)	100%	A	A	A	N
Chlorhydric acid	10%, 180	N	N	A	
Chlorhydric acid	100%, 20	N	N	A	
Hydrosilicofluoric acid	100%	N	B	N	
Hydrosilicofluoric acid	35%	N	B	N	B
Hydrobromic acid	50%	N	N	A	N
Chlorhydric acid	10%, 60	N	N	A	
Hydrobromic acid	98%, 20	N	N	N	A
Ammonocarbonous acid	100%	B	B	A	
Hydrogen peroxide	50%	B	B	A	
Glycolic acid	35%	B	B	A	N
Glycolic acid	70%	B	B	A	
Hypochloric acid	20%	N	B	A	

Ferric chloride	100%	N	B	A	A
Ferric nitrate	100%	N	B	A	
Ferric sulfate	100%	N	B	A	
Lead acetate	100%	N	N	A	
Aluminium chloride	100%	N	N	B	A
Magnesium chloride	40%	N	N	B	A
Magnesium carbonate	10%	B	B	B	A
Magnesium bisulfite	100%	B	B	B	
Magnesium hydrate	100%	N	N	N	N
Magnesium nitrate	100%	N	N	N	A
Magnesium sulfate	100%	B	B	N	A
Mercuric chloride	60%	N	N	N	A
Nickel dichloride	20%	N	N	N	B
Nickel nitrate	10%	N	N	N	A
Nickel vitriol	100%	N	N	N	A
Aqua fortis	10%, 100	B	B	A	A
Aqua fortis	60%, 100	N	N	B	A
Aqua fortis	70%, 70	N	N	N	A
Aqua fortis	98%, 30	N	N	N	A
Oxalic acid	100%	N	N	N	A

A--first adoption B—available N—unusable (for indication only)

Note: 1. without special explanation, liquid temperature can reach 100 .

2. all liquid mentioned in the table is with pure ingredient.

WP- series electromagnetic flow sensor has been inspected by NEPSI, products meet requirements of GB3836.1— 2000, GB3836.2— 2000 standard, its explosion-proof mark is Exd II CT6, explosion-proof certificate NO. CNEx07.2285. Product application must follow the items:

Product application ambient temperature: -10 ~ +60 ;

Field application must follow the warning of “open the cap after power off”;

the outer diameter of entrance cable is 8~ 8.5 mm (seal ring diameter 8.5) and 9~ 10 mm (seal ring diameter 10). Field application must tighten and hold down nuts so that seal ring cling to cable sheath

When using the product, shell can approach ground;

Users cannot change product parts by themselves;

The anterior pole of electrode of the product must equip LB910P zener safety barrier, in order to composite intrinsic safety and explosion prevention system;

The routing of intrinsic safety and explosion prevention system should avoid influence of exterior EMI, and control cable distributed parameter within 3.0 μ F/ 0.39 Mh;

Relationship between the product explosion-proof temperature group and medium temperature: T6 – temperature 80 ;

Installation, use and maintenance of the product should simultaneously follow the product operating manual, GB3836.15-2000 “ Electrical apparatus for explosive gas atmospheres—Part

15: electrical installation in hazardous area (coal mine excepted) ” and related regulations of GB50058-1992 “ Electrical installations design code for explosive atmospheres and fire hazard”.